

Rexroth GTE Planetary Gearboxes

R911308842
Edition 06

Project Planning Manual

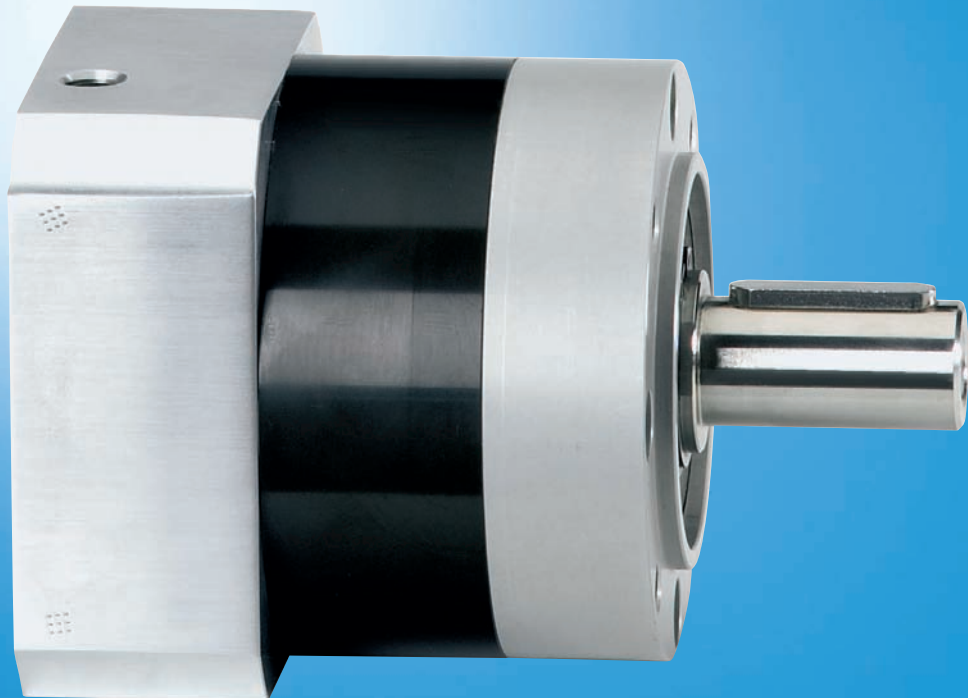

Title Rexroth GTE
Planetary Gearboxes

Type of Documentation Project Planning Manual

Document Typecode DOK-GEAR**-GTE*****-PR06-EN-P

Internal File Reference RS-20ad79a1d989be610a6846a0004ed7c2-3-en-US-12

Record of Revision

Edition	Release Date	Notes
DOK-GEAR**-GTE*****-PR01-EN-P	12/2004	First edition
DOK-GEAR**-GTE*****-PR02-EN-P	04/2005	Revision
DOK-GEAR**-GTE*****-PR03-EN-P	01/2006	Revision
DOK-GEAR**-GTE*****-PR04-EN-P	07/2009	Revision
DOK-GEAR**-GTE*****-PR05-EN-P	11/2009	Revision
DOK-GEAR**-GTE*****-PR06-EN-P	05/2010	Revision type code

Copyright © Bosch Rexroth AG, 2009

Copying this document, giving it to others and the use or communication of the contents thereof without express authority, are forbidden. Offenders are liable for the payment of damages. All rights are reserved in the event of the grant of a patent or the registration of a utility model or design (DIN 34-1).

Validity The specified data is for product description purposes only and may not be deemed to be guaranteed unless expressly confirmed in the contract. All rights are reserved with respect to the content of this documentation and the availability of the product.

Published by Bosch Rexroth AG
Bgm.-Dr.-Nebel-Str. 2 ■ 97816 Lohr a. Main, Germany
Phone +49 (0)93 52 / 40-0 ■ Fax +49 (0)93 52 / 40-48 85
<http://www.boschrexroth.com/>
Dept.DCC/EDM (MB)

Note This document has been printed on chlorine-free bleached paper.

Table of Contents

	Page
1 Introduction to the Product.....	5
1.1 GTE Planetary Gearboxes.....	5
1.2 About this Documentation.....	7
1.2.1 General Information.....	7
1.2.2 Standards.....	7
2 Important Instructions on Use.....	9
2.1 Intended Use.....	9
2.1.1 General Information.....	9
2.1.2 Areas of Use and Application.....	9
2.2 Non-Intended Use.....	10
3 Safety Instructions for Electric Drives and Controls	11
3.1 Definitions of Terms.....	11
3.2 General Information.....	12
3.2.1 Using the Safety Instructions and Passing Them on to Others.....	12
3.2.2 Requirements for Safe Use.....	12
3.2.3 Hazards by Improper Use.....	13
3.3 Instructions with Regard to Specific Dangers.....	14
3.3.1 Protection Against Contact with Electrical Parts and Housings.....	14
3.3.2 Protective Extra-Low Voltage as Protection Against Electric Shock	15
3.3.3 Protection Against Dangerous Movements.....	15
3.3.4 Protection Against Magnetic and Electromagnetic Fields During Operation and Mounting.....	17
3.3.5 Protection Against Contact With Hot Parts.....	17
3.3.6 Protection During Handling and Mounting.....	17
3.3.7 Battery Safety.....	18
3.3.8 Protection Against Pressurized Systems.....	18
3.4 Explanation of Signal Words and the Safety Alert Symbol.....	19
4 Dimensioning and Selection.....	21
4.1 Dimensioning.....	21
4.2 Selection.....	22
5 Application Notes	25
5.1 Operating Conditions.....	25
5.1.1 General Information.....	25
5.1.2 Operating Mode S5 (Intermitted Operation).....	26
5.1.3 Operating Mode S1 (Continuous Operation)	26
5.2 Operating Gearboxes or Motor-Gearbox Combinations in Hazardous Areas (ATEX).....	26
5.3 Mechanical Features.....	27
5.4 Combination Possibilities of GTE Planetary Gearboxes with Motors.....	29

Table of Contents

	Page
6	Technical Data..... 31
6.1	Technical Data for Intermittent and Continuous Operation..... 31
6.2	Maximum Transferable Output Torque..... 35
6.3	Thermal Specifications for S1 Operation..... 36
6.4	Technical Data at Increased Lifetime..... 37
6.5	Limiting Temperature Curves to Determine Higher S1-Speed..... 37
6.6	Permitted Shaft Load..... 43
6.7	GTE040..... 44
6.8	GTE060..... 45
6.9	GTE080..... 46
6.10	GTE120..... 47
6.11	GTE160..... 48
7	Specifications..... 49
7.1	GTE040..... 49
7.2	GTE060..... 50
7.3	GTE080..... 51
7.4	GTE120..... 52
7.5	GTE160..... 53
8	Type Codes..... 55
8.1	Notes on Connecting a Motor acc. to ATEX Standard..... 55
8.2	Type Code GTE040..... 55
8.3	Type Code GTE060..... 56
8.4	Type Code GTE080..... 57
8.5	Type Code GTE120..... 58
8.6	Type Code GTE160..... 59
9	Handling, Transport and Storage..... 61
9.1	Handling..... 61
9.1.1	Identifying the Goods..... 61
9.1.2	Name Plates..... 61
9.2	Transport and Storage..... 62
10	Mounting..... 65
10.1	Skilled Personnel..... 65
10.2	Motor Mounting..... 65
10.2.1	General Information..... 65
10.2.2	Mounting Procedure..... 65
10.3	Gearbox Mounting..... 68
11	Commissioning, Operation and Maintenance..... 69
11.1	Start-Up..... 69
11.1.1	General Information..... 69

Table of Contents

	Page
11.1.2	Preparation..... 69
11.1.3	Bulk Head Connector..... 69
11.2	Deactivation..... 70
11.3	Disassembly..... 70
11.4	Maintenance..... 70
11.4.1	General Information..... 70
11.4.2	Measures..... 71
11.5	Troubleshooting 71
11.5.1	General Information..... 71
11.5.2	Excess Temperature of Gearbox Housing..... 71
11.5.3	Gearbox-Motor Unit Generates Vibrations..... 72
11.5.4	Specified Position is not Attained..... 72
12	Ordering Designations..... 73
12.1	General Information..... 73
12.2	Notes on Connecting a Motor acc. to ATEX Standard..... 73
13	"Old" Technical Data..... 75
13.1	"Old" Technical Data for Intermittent and Continuous Operation..... 75
14	Environmental Protection and Disposal 79
14.1	Environmental Protection..... 79
14.2	Disposal..... 79
15	Service and Support..... 81
	Index..... 83

1 Introduction to the Product

1.1 GTE Planetary Gearboxes



Fig. 1-1: Mounting example: GTE planetary gearboxes mounted on IndraDyn S motors

Application In combination with the drive and control system of Rexroth, GTE planetary gearboxes provide a low-cost automation system for various sectors of industry. They are well-suited for use with gear racks or toothed belts in handling systems with high speed and accelerations (e.g.: loader and robots).
The low-backlash with shave-grinded (honed) planet wheels permits the execution of exact positioning tasks. Furthermore, the gearboxes are suited for S1-operation-required for application in e.g. the printing sector.

Introduction to the Product

Gradations

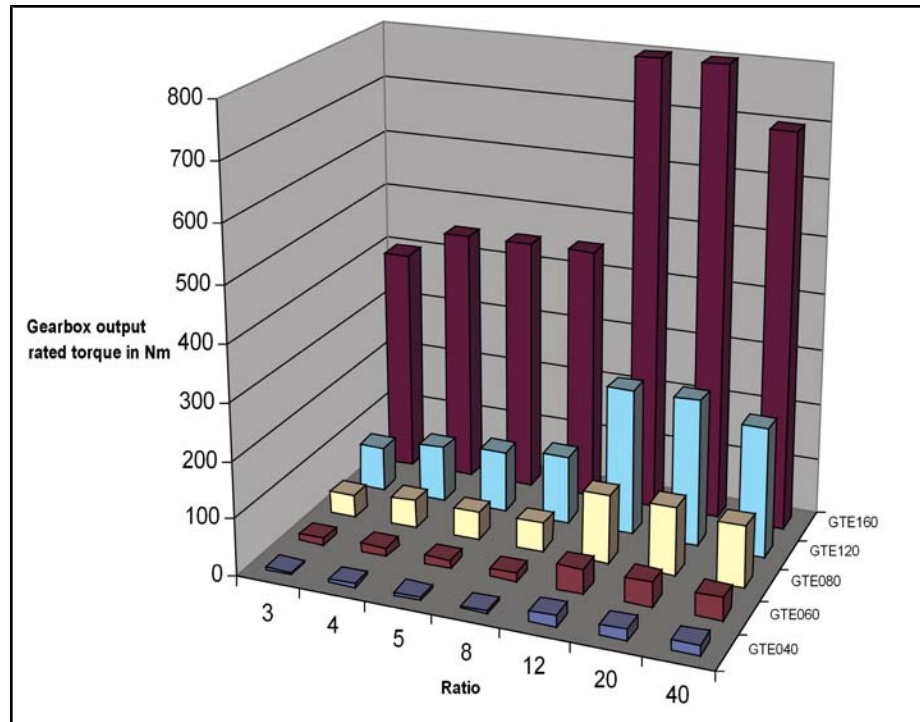

Fig.1-2: Nominal torque gradation of GTE planetary gearboxes

Mode of Functioning

The GTE series of planetary gearboxes offers a coaxial input and output. The output shaft of the motor is connected to the sun gear with a non-positive compression clamp coupling. This sun gear drives three planetary wheels, which roll off on an internal gear with internal gear teeth, as a single-stage gearbox and four planetary wheels as a two-stage gearbox. The planetary gears are fixed in the planet carrier, which acts as the output. By dividing the load among the planetary gear on three or four planetary wheels, a balanced force splitting occurs. This allows for a very compact gearbox with a high power density.

High Operational Reliability

- Maintenance-free operation through lifetime lubrication
- Use under adverse environmental conditions is possible due to the completely enclosed IP54 design.
- Safe and lasting sealing by abrasion bearing sealants.
- Hermetically sealed housing
- Non-positive from backlash-free torque transmission via the compression coupling

High Performance Data

- High accuracy via shave grinded (honed) planetary wheels, low backlash gearing with low torque play.
- High efficiency, low temperature and minimum power loss made possible by using the smallest possible seal diameters.
- Low running noise by optimized gear profiles.
- High emergency stop torque made possible by internal transferred power.
- Highly dynamic because of inertia
- Low weight through compact design

Easy to Mount to Machine

- The high radial-load capability and tilt resistance makes it possible to directly mount a pinion or pulley.
- The design of the output shaft with a solid shaft shoulder makes axial tightening of output elements simple.

- The gearbox can be mounted in any position. Due to the defined bearing position and pump current a sufficient lubricant supply is always ensured.
- The output elements can be mounted in two different ways:
 - non-positive shaft-hub connection by means of a plain output hollow shaft, or
 - connection by means of an output shaft with keyway

1.2 About this Documentation

1.2.1 General Information

This document contains safety regulations, technical data, and operating instructions for gearboxes. The individual chapters can be subdivided into the following focal points:

Chapter	Title	Contents
1	Introduction to the Product	General Information
2	Important Instructions on Use	Safety
3	Notes Regarding Safety	
4	Dimensioning and Selection	Product description (for planners and designers)
5	Application Notes	
6	technical data	
7	Specifications	
8	Type Codes	
9	Handling, Transport and Storage	Practise (for operating and maintenance personnel)
10	Assembly	
11	Commissioning, Operation and Maintenance	
12	Ordering Data	
13	Appendix	General Information
14	Service & Support	
15	Index	

Fig. 1-3: Document structure

1.2.2 Standards

This documentation refers to German, European and international technical standards. Documents and sheets on standards underlie the protection by copyright and may not be passed on to third parties by REXROTH INDRAMAT. If need be, please contact the authorized sales outlets or, in Germany, directly:

BEUTH Verlag GmbH
Burggrafenstrasse 6

Introduction to the Product

10787 Berlin, Germany

Phone +49 (0) 30 – 26 01-22 60, Fax +49 (0) 30 – 26 01-12 60

Internet: <http://www.din.be/beuth>

Email: postmaster@beuth.de

Your Feedback

Your experiences are an essential part of the process of improving both the product and the documentation.

Please do not hesitate to inform us of any error you detect in this documentation or of any modifications you might desire. We would appreciate your feedback.

Please send your remarks to:

Bosch Rexroth AG

Dept. DCC/EDM1

Buergermeister-Dr.-Nebel-Strasse 2

97816 Lohr am Main, Germany

Fax +49 (0) 93 52 / 40 43 80

2 Important Instructions on Use

2.1 Intended Use

2.1.1 General Information

Introduction Rexroth products are developed and manufactured according to the state of the art. Before they are delivered, they are inspected to ensure that they operate safely.

The products must only be used as intended. If they are inappropriately used, situations may arise resulting in injuries to property and persons.



Rexroth, as the manufacturer, does not provide any warranty, assume any liability, or pay any damages for damage caused by products not being used as intended. Any risks resulting from the products not being used as intended are the sole responsibility of the user.

Before using the Bosch Rexroth products, the following condition precedent must be fulfilled so as to ensure that they are used as intended:

- Everyone who in any way whatsoever handles one of our products must read and understand the corresponding notes regarding safety and regarding the intended use.
- If the products are hardware, they must be kept in their original state, i.e. no constructional modifications must be made. Software products must not be decompiled; their source codes must not be modified.
- Damaged or improperly working products must not be installed or put into operation.
- It must be ensured that the products are installed according to the regulations specified in the documentation.

2.1.2 Areas of Use and Application

Typical application ranges of the GTE planetary gearboxes are:

- Handling and Mounting systems,
- Packaging and Food-processing machines,
- Printing and Paper-processing machines and

Controlling and monitoring of the motor/-gearbox combination may require connection of additional sensors and actuators.



The gearboxes may only be used with the accessories specified in the documentation. Components that are not explicitly mentioned must neither be attached nor connected. The same is true for cables and lines.



The operation must only be carried out in the explicitly mentioned configurations and combinations of the component and with the software and firmware specified in the corresponding functional description.

Any drive controller must be programmed before startup, in order to ensure that the motor executes the functions specific to the particular application.

Important Instructions on Use

The gearboxes may only be operated under the assembly, mounting and installation conditions, in the normal position, and under the environmental conditions (temperature, degree of protection, humidity, EMC, and the like) specified in this documentation.

2.2 Non-Intended Use

Any use of gearboxes outside of the fields of application mentioned above or under operating conditions and technical data other than those specified in this documentation is considered as "non-intended use".

Planetary gearboxes may not be used if . . .

- They are subject to operating conditions which do not comply with the ambient conditions described above. E.g. operation under water, under extreme variations in temperature or extreme maximum temperatures is not permitted.
- the intended application is not explicitly released by Bosch Rexroth. Please make absolutely sure that the instructions given in the general safety notes are also complied with!

3 Safety Instructions for Electric Drives and Controls

3.1 Definitions of Terms

Application Documentation	Application documentation comprises the entire documentation used to inform the user of the product about the use and safety-relevant features for configuring, integrating, installing, mounting, commissioning, operating, maintaining, repairing and decommissioning the product. The following terms are also used for this kind of documentation: User Guide, Operation Manual, Commissioning Manual, Instruction Manual, Project Planning Manual, Application Manual, etc.
Component	A component is a combination of elements with a specified function, which are part of a piece of equipment, device or system. Components of the electric drive and control system are, for example, supply units, drive controllers, mains choke, mains filter, motors, cables, etc.
Control System	A control system comprises several interconnected control components placed on the market as a single functional unit.
Device	A device is a finished product with a defined function, intended for users and placed on the market as an individual piece of merchandise.
Electrical Equipment	Electrical equipment encompasses all devices used to generate, convert, transmit, distribute or apply electrical energy, such as electric motors, transformers, switching devices, cables, lines, power-consuming devices, circuit board assemblies, plug-in units, control cabinets, etc.
Electric Drive System	An electric drive system comprises all components from mains supply to motor shaft; this includes, for example, electric motor(s), motor encoder(s), supply units and drive controllers, as well as auxiliary and additional components, such as mains filter, mains choke and the corresponding lines and cables.
Installation	An installation consists of several devices or systems interconnected for a defined purpose and on a defined site which, however, are not intended to be placed on the market as a single functional unit.
Machine	A machine is the entirety of interconnected parts or units at least one of which is movable. Thus, a machine consists of the appropriate machine drive elements, as well as control and power circuits, which have been assembled for a specific application. A machine is, for example, intended for processing, treatment, movement or packaging of a material. The term "machine" also covers a combination of machines which are arranged and controlled in such a way that they function as a unified whole.
Manufacturer	The manufacturer is an individual or legal entity bearing responsibility for the design and manufacture of a product which is placed on the market in the individual's or legal entity's name. The manufacturer can use finished products, finished parts or finished elements, or contract out work to subcontractors. However, the manufacturer must always have overall control and possess the required authority to take responsibility for the product.
Product	Examples of a product: Device, component, part, system, software, firmware, among other things.
Project Planning Manual	A project planning manual is part of the application documentation used to support the sizing and planning of systems, machines or installations.
Qualified Persons	In terms of this application documentation, qualified persons are those persons who are familiar with the installation, mounting, commissioning and operation of the components of the electric drive and control system, as well as with the hazards this implies, and who possess the qualifications their work requires. To comply with these qualifications, it is necessary, among other things,

Safety Instructions for Electric Drives and Controls

- 1) to be trained, instructed or authorized to switch electric circuits and devices safely on and off, to ground them and to mark them
- 2) to be trained or instructed to maintain and use adequate safety equipment
- 3) to attend a course of instruction in first aid

User A user is a person installing, commissioning or using a product which has been placed on the market.

3.2 General Information

3.2.1 Using the Safety Instructions and Passing Them on to Others

Do not attempt to install and operate the components of the electric drive and control system without first reading all documentation provided with the product. Read and understand these safety instructions and all user documentation prior to working with these components. If you do not have the user documentation for the components, contact your responsible Rexroth sales partner. Ask for these documents to be sent immediately to the person or persons responsible for the safe operation of the components.

If the component is resold, rented and/or passed on to others in any other form, these safety instructions must be delivered with the component in the official language of the user's country.

Improper use of these components, failure to follow the safety instructions in this document or tampering with the product, including disabling of safety devices, could result in property damage, injury, electric shock or even death.

3.2.2 Requirements for Safe Use

Read the following instructions before initial commissioning of the components of the electric drive and control system in order to eliminate the risk of injury and/or property damage. You must follow these safety instructions.

- Rexroth is not liable for damages resulting from failure to observe the safety instructions.
- Read the operating, maintenance and safety instructions in your language before commissioning. If you find that you cannot completely understand the application documentation in the available language, please ask your supplier to clarify.
- Proper and correct transport, storage, mounting and installation, as well as care in operation and maintenance, are prerequisites for optimal and safe operation of the component.
- Only qualified persons may work with components of the electric drive and control system or within its proximity.
- Only use accessories and spare parts approved by Rexroth.
- Follow the safety regulations and requirements of the country in which the components of the electric drive and control system are operated.
- Only use the components of the electric drive and control system in the manner that is defined as appropriate. See chapter "Appropriate Use".
- The ambient and operating conditions given in the available application documentation must be observed.
- Applications for functional safety are only allowed if clearly and explicitly specified in the application documentation "Integrated Safety Technology". If this is not the case, they are excluded. Functional safety is a safety

Safety Instructions for Electric Drives and Controls

concept in which measures of risk reduction for personal safety depend on electrical, electronic or programmable control systems.

- The information given in the application documentation with regard to the use of the delivered components contains only examples of applications and suggestions.

The machine and installation manufacturers must

- make sure that the delivered components are suited for their individual application and check the information given in this application documentation with regard to the use of the components,
 - make sure that their individual application complies with the applicable safety regulations and standards and carry out the required measures, modifications and complements.
- Commissioning of the delivered components is only allowed once it is sure that the machine or installation in which the components are installed complies with the national regulations, safety specifications and standards of the application.
 - Operation is only allowed if the national EMC regulations for the application are met.
 - The instructions for installation in accordance with EMC requirements can be found in the section on EMC in the respective application documentation.

The machine or installation manufacturer is responsible for compliance with the limit values as prescribed in the national regulations.

- The technical data, connection and installation conditions of the components are specified in the respective application documentations and must be followed at all times.

National regulations which the user must take into account

- European countries: In accordance with European EN standards
- United States of America (USA):
 - National Electrical Code (NEC)
 - National Electrical Manufacturers Association (NEMA), as well as local engineering regulations
 - Regulations of the National Fire Protection Association (NFPA)
- Canada: Canadian Standards Association (CSA)
- Other countries:
 - International Organization for Standardization (ISO)
 - International Electrotechnical Commission (IEC)

3.2.3 Hazards by Improper Use

- High electrical voltage and high working current! Danger to life or serious injury by electric shock!
- High electrical voltage by incorrect connection! Danger to life or injury by electric shock!
- Dangerous movements! Danger to life, serious injury or property damage by unintended motor movements!
- Health hazard for persons with heart pacemakers, metal implants and hearing aids in proximity to electric drive systems!
- Risk of burns by hot housing surfaces!

Safety Instructions for Electric Drives and Controls

- Risk of injury by improper handling! Injury by crushing, shearing, cutting, hitting!
- Risk of injury by improper handling of batteries!
- Risk of injury by improper handling of pressurized lines!

3.3 Instructions with Regard to Specific Dangers

3.3.1 Protection Against Contact with Electrical Parts and Housings



This section concerns components of the electric drive and control system with voltages of **more than 50 volts**.

Contact with parts conducting voltages above 50 volts can cause personal danger and electric shock. When operating components of the electric drive and control system, it is unavoidable that some parts of these components conduct dangerous voltage.

High electrical voltage! Danger to life, risk of injury by electric shock or serious injury!

- Only qualified persons are allowed to operate, maintain and/or repair the components of the electric drive and control system.
- Follow the general installation and safety regulations when working on power installations.
- Before switching on, the equipment grounding conductor must have been permanently connected to all electric components in accordance with the connection diagram.
- Even for brief measurements or tests, operation is only allowed if the equipment grounding conductor has been permanently connected to the points of the components provided for this purpose.
- Before accessing electrical parts with voltage potentials higher than 50 V, you must disconnect electric components from the mains or from the power supply unit. Secure the electric component from reconnection.
- With electric components, observe the following aspects:
 - Always wait **30 minutes** after switching off power to allow live capacitors to discharge before accessing an electric component. Measure the electrical voltage of live parts before beginning to work to make sure that the equipment is safe to touch.
- Install the covers and guards provided for this purpose before switching on.
- Never touch electrical connection points of the components while power is turned on.
- Do not remove or plug in connectors when the component has been powered.
- Under specific conditions, electric drive systems can be operated at mains protected by residual-current-operated circuit-breakers sensitive to universal current (RCDs/RCMs).
- Secure built-in devices from penetrating foreign objects and water, as well as from direct contact, by providing an external housing, for example a control cabinet.

High housing voltage and high leakage current! Danger to life, risk of injury by electric shock!

- Before switching on and before commissioning, ground or connect the components of the electric drive and control system to the equipment grounding conductor at the grounding points.
- Connect the equipment grounding conductor of the components of the electric drive and control system permanently to the main power supply at all times. The leakage current is greater than 3.5 mA.
- Establish an equipment grounding connection with a copper wire of a cross section of at least 10 mm² (8 AWG) or additionally run a second equipment grounding conductor of the same cross section as the original equipment grounding conductor.

3.3.2 Protective Extra-Low Voltage as Protection Against Electric Shock

Protective extra-low voltage is used to allow connecting devices with basic insulation to extra-low voltage circuits.

On components of an electric drive and control system provided by Rexroth, all connections and terminals with voltages between 5 and 50 volts are PELV ("Protective Extra-Low Voltage") systems. It is allowed to connect devices equipped with basic insulation (such as programming devices, PCs, notebooks, display units) to these connections.

Danger to life, risk of injury by electric shock! High electrical voltage by incorrect connection!

If extra-low voltage circuits of devices containing voltages and circuits of more than 50 volts (e.g., the mains connection) are connected to Rexroth products, the connected extra-low voltage circuits must comply with the requirements for PELV ("Protective Extra-Low Voltage").

3.3.3 Protection Against Dangerous Movements

Dangerous movements can be caused by faulty control of connected motors. Some common examples are:

- Improper or wrong wiring or cable connection
- Operator errors
- Wrong input of parameters before commissioning
- Malfunction of sensors and encoders
- Defective components
- Software or firmware errors

These errors can occur immediately after equipment is switched on or even after an unspecified time of trouble-free operation.

The monitoring functions in the components of the electric drive and control system will normally be sufficient to avoid malfunction in the connected drives. Regarding personal safety, especially the danger of injury and/or property damage, this alone cannot be relied upon to ensure complete safety. Until the integrated monitoring functions become effective, it must be assumed in any case that faulty drive movements will occur. The extent of faulty drive movements depends upon the type of control and the state of operation.

Safety Instructions for Electric Drives and Controls

Dangerous movements! Danger to life, risk of injury, serious injury or property damage!

A **risk assessment** must be prepared for the installation or machine, with its specific conditions, in which the components of the electric drive and control system are installed.

As a result of the risk assessment, the user must provide for monitoring functions and higher-level measures on the installation side for personal safety. The safety regulations applicable to the installation or machine must be taken into consideration. Unintended machine movements or other malfunctions are possible if safety devices are disabled, bypassed or not activated.

To avoid accidents, injury and/or property damage:

- Keep free and clear of the machine's range of motion and moving machine parts. Prevent personnel from accidentally entering the machine's range of motion by using, for example:
 - Safety fences
 - Safety guards
 - Protective coverings
 - Light barriers
- Make sure the safety fences and protective coverings are strong enough to resist maximum possible kinetic energy.
- Mount emergency stopping switches in the immediate reach of the operator. Before commissioning, verify that the emergency stopping equipment works. Do not operate the machine if the emergency stopping switch is not working.
- Prevent unintended start-up. Isolate the drive power connection by means of OFF switches/OFF buttons or use a safe starting lockout.
- Make sure that the drives are brought to safe standstill before accessing or entering the danger zone.
- Additionally secure vertical axes against falling or dropping after switching off the motor power by, for example,
 - mechanically securing the vertical axes,
 - adding an external braking/arrester/clamping mechanism or
 - ensuring sufficient counterbalancing of the vertical axes.
- The standard equipment **motor holding brake** or an external holding brake controlled by the drive controller is **not sufficient to guarantee personal safety!**
- Disconnect electrical power to the components of the electric drive and control system using the master switch and secure them from reconnection ("lock out") for:
 - Maintenance and repair work
 - Cleaning of equipment
 - Long periods of discontinued equipment use
- Prevent the operation of high-frequency, remote control and radio equipment near components of the electric drive and control system and their supply leads. If the use of these devices cannot be avoided, check the machine or installation, at initial commissioning of the electric drive and control system, for possible malfunctions when operating such high-frequency, remote control and radio equipment in its possible positions of normal use. It might possibly be necessary to perform a special electromagnetic compatibility (EMC) test.

3.3.4 Protection Against Magnetic and Electromagnetic Fields During Operation and Mounting

Magnetic and electromagnetic fields generated by current-carrying conductors or permanent magnets of electric motors represent a serious danger to persons with heart pacemakers, metal implants and hearing aids.

Health hazard for persons with heart pacemakers, metal implants and hearing aids in proximity to electric components!

- Persons with heart pacemakers and metal implants are not allowed to enter the following areas:
 - Areas in which components of the electric drive and control systems are mounted, commissioned and operated.
 - Areas in which parts of motors with permanent magnets are stored, repaired or mounted.
- If it is necessary for somebody with a heart pacemaker to enter such an area, a doctor must be consulted prior to doing so. The noise immunity of implanted heart pacemakers differs so greatly that no general rules can be given.
- Those with metal implants or metal pieces, as well as with hearing aids, must consult a doctor before they enter the areas described above.

3.3.5 Protection Against Contact With Hot Parts

Hot surfaces of components of the electric drive and control system. Risk of burns!

- Do not touch hot surfaces of, for example, braking resistors, heat sinks, supply units and drive controllers, motors, windings and laminated cores!
- According to the operating conditions, temperatures of the surfaces can be **higher than 60 °C (140 °F)** during or after operation.
- Before touching motors after having switched them off, let them cool down for a sufficient period of time. Cooling down can require **up to 140 minutes!** The time required for cooling down is approximately five times the thermal time constant specified in the technical data.
- After switching chokes, supply units and drive controllers off, wait **15 minutes** to allow them to cool down before touching them.
- Wear safety gloves or do not work at hot surfaces.
- For certain applications, and in accordance with the respective safety regulations, the manufacturer of the machine or installation must take measures to avoid injuries caused by burns in the final application. These measures can be, for example: Warnings at the machine or installation, guards (shieldings or barriers) or safety instructions in the application documentation.

3.3.6 Protection During Handling and Mounting

Risk of injury by improper handling! Injury by crushing, shearing, cutting, hitting!

- Observe the relevant statutory regulations of accident prevention.
- Use suitable equipment for mounting and transport.
- Avoid jamming and crushing by appropriate measures.

Safety Instructions for Electric Drives and Controls

- Always use suitable tools. Use special tools if specified.
- Use lifting equipment and tools in the correct manner.
- Use suitable protective equipment (hard hat, safety goggles, safety shoes, safety gloves, for example).
- Do not stand under hanging loads.
- Immediately clean up any spilled liquids from the floor due to the risk of slipping.

3.3.7 Battery Safety

Batteries consist of active chemicals in a solid housing. Therefore, improper handling can cause injury or property damage.

Risk of injury by improper handling!

- Do not attempt to reactivate low batteries by heating or other methods (risk of explosion and cauterization).
- Do not attempt to recharge the batteries as this may cause leakage or explosion.
- Do not throw batteries into open flames.
- Do not dismantle batteries.
- When replacing the battery/batteries, do not damage the electrical parts installed in the devices.
- Only use the battery types specified for the product.



Environmental protection and disposal! The batteries contained in the product are considered dangerous goods during land, air, and sea transport (risk of explosion) in the sense of the legal regulations. Dispose of used batteries separately from other waste. Observe the national regulations of your country.

3.3.8 Protection Against Pressurized Systems

According to the information given in the Project Planning Manuals, motors and components cooled with liquids and compressed air can be partially supplied with externally fed, pressurized media, such as compressed air, hydraulics oil, cooling liquids and cooling lubricants. Improper handling of the connected supply systems, supply lines or connections can cause injuries or property damage.

Risk of injury by improper handling of pressurized lines!

- Do not attempt to disconnect, open or cut pressurized lines (risk of explosion).
- Observe the respective manufacturer's operating instructions.
- Before dismounting lines, relieve pressure and empty medium.
- Use suitable protective equipment (safety goggles, safety shoes, safety gloves, for example).
- Immediately clean up any spilled liquids from the floor due to the risk of slipping.



Environmental protection and disposal! The agents (e.g., fluids) used to operate the product might not be environmentally friendly. Dispose of agents harmful to the environment separately from other waste. Observe the national regulations of your country.

3.4 Explanation of Signal Words and the Safety Alert Symbol

The Safety Instructions in the available application documentation contain specific signal words (DANGER, WARNING, CAUTION or NOTICE) and, where required, a safety alert symbol (in accordance with ANSI Z535.6-2006).

The signal word is meant to draw the reader's attention to the safety instruction and identifies the hazard severity.

The safety alert symbol (a triangle with an exclamation point), which precedes the signal words DANGER, WARNING and CAUTION, is used to alert the reader to personal injury hazards.

DANGER

In case of non-compliance with this safety instruction, death or serious injury will occur.

WARNING

In case of non-compliance with this safety instruction, death or serious injury could occur.

CAUTION

In case of non-compliance with this safety instruction, minor or moderate injury could occur.

NOTICE

In case of non-compliance with this safety instruction, property damage could occur.

4 Dimensioning and Selection

4.1 Dimensioning

Applications for GTE planetary gearboxes are characterized by the following speed-time-curves:

- Triangular speed curve with pause interval
- Operation with constant speed and pause interval
- Operation with trapezoidal speed curve and pause interval
- Continuous operation without pause interval (S1)

The speed-time curves define the dimension criteria.

Triangular operation with pause interval

This operating mode is characteristic for all highly-dynamic feeds. These are often found in roll-feed mechanisms in the sheet-metal, paper, plastic and packaging industries.

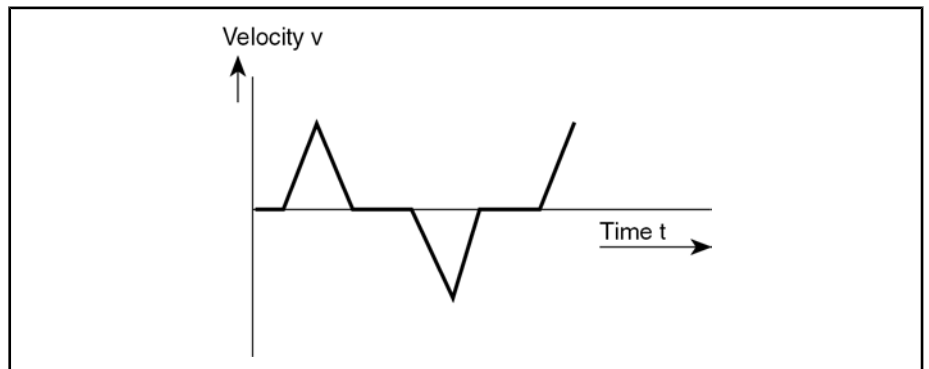

Fig. 4-1: Speed-time curve for triangle operation

The dimensioning of this operation is mainly made according to the necessary maximum torque M_{max} and the average velocity $V_{average}$ resp. mean speed $n_{average}$.

Continuous Operation with Pause Interval

This operation is characteristic for all highly-dynamic feeds. These are often found in winding machines, drive rolls and in portioning devices in the sheet-metal, paper, plastic and packaging industry.

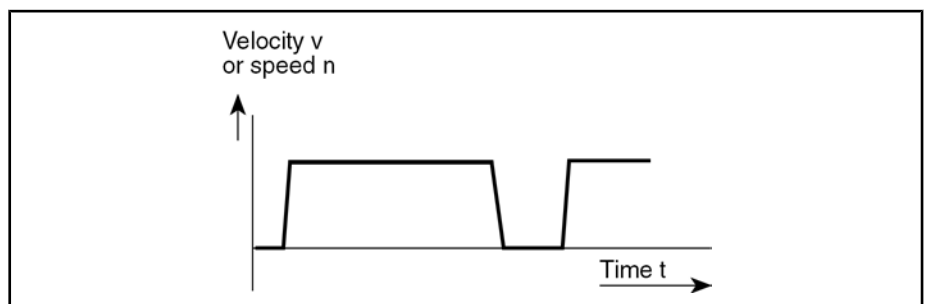

Fig. 4-2: Speed-time diagram for operation with constant speed

The dimensioning of this operation is mainly made according to the necessary maximum torque M_{max} and the average velocity $V_{average}$ resp. mean speed $n_{average}$.

Triangular Operation with Pause Interval

This mode of operation is characteristic for the most highly-dynamic feeds. They can be found in loaders and handling systems in nearly all industry sectors.

Dimensioning and Selection

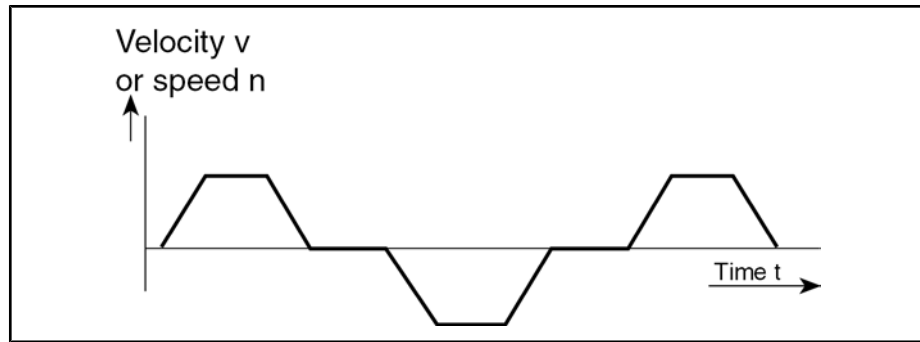

Fig.4-3: Speed-time-graph for triangle operation

The dimensioning of this operation is mainly made according to the necessary maximum torque M_{\max} and the average velocity V_{average} resp. mean speed n_{average} .

Continuous operation without pause interval (S1)

This mode of operation is characteristic for drives in printing machines.

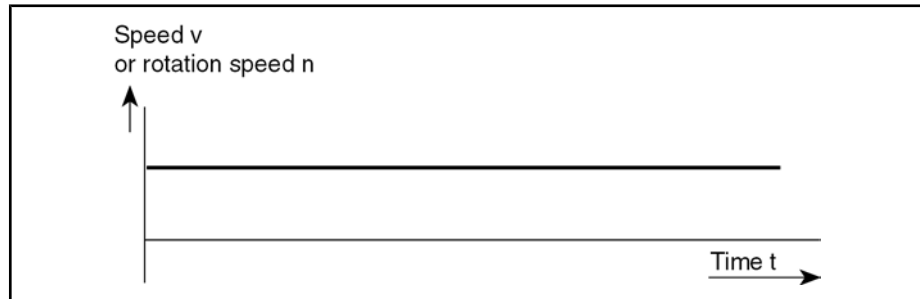

Fig.4-4: Speed-time graph for constant speed

The dimensioning is made according to the necessary continuous torque M_{dN} and the velocity v or the speed n .

4.2 Selection

Drive-Determined Sizes

The selection of the suitable motor/-gearbox combination, operating with a drive control device, is to be taking in the following into consideration:

- Frictional torque
- Starting torque
- Processing torque
- Accelerating torque
- Effective speed
- Necessary speed
- ON time

Dimensioning Criteria

The motor-gearbox combination must fulfill the following conditions:

- The necessary speed must be reached.
- The continuous torque rating of the motor-gearbox combination has to be higher than the effective load torque.
- The intermittent torque has to be higher than the sum of the frictional, starting and processing torque.
- The maximum torque has to be higher than the sum of frictional, weight and processing torque.
- The required acceleration time has to be within the limit of the relevant drive selection lists.

Dimensioning and Selection

- The thermal use-limit of the motor-gearbox combination must be adhered.
- The cycles of the operation modes S4 and S5 should not exceed 1,000 cycles per hour. If higher cycle rates are necessary, the GTM gearbox must be derated accordingly (see Fig. 5-3).



It must be ensured that

- the maximum motor torque is smaller than the maximum gearbox – input torque.
 - the maximum motor speed is smaller than the maximum permissible gearbox-input speed.
-

5 Application Notes

5.1 Operating Conditions

5.1.1 General Information

**Maximum Ambient Temperature,
 Maximum Setup Elevation**

The power conductors as stated in the selection data will be reached at the following conditions:

Ambient temperature: 0...+86.00°F

Setup elevation: 0...1,000 m above sea level

The power data is reduced according to the diagram below at deviating conditions. Do occur deviating ambient temperatures and higher setup elevations at the same time, the power data has to be multiplied with both factors.

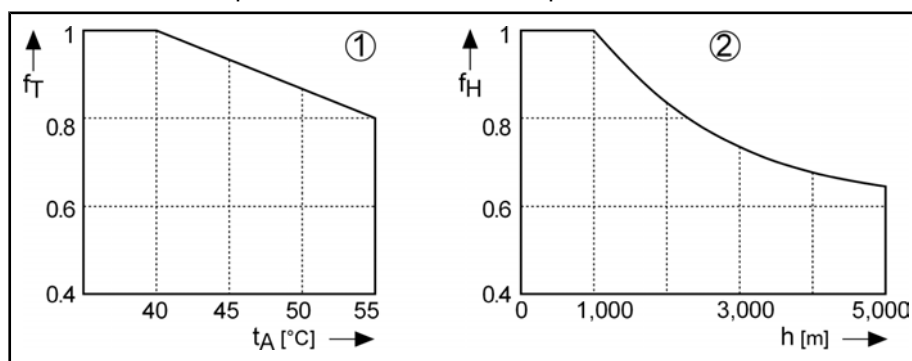

1 Utilization at a higher ambient temperature of more than 86.00°F.

2 Utilization at a higher setup elevation than 1,000 m.

Fig. 5-1: Utilization at higher ambient temperature and higher setup elevation

Protection Class

According to DIN EN 60529-1:2000-09, the motor with mounted GTE planetary gearbox is protected by the housing against

- contact of parts under load or moving parts
- Penetration of firm foreign bodies and water

At motors and the mounted servo gearboxes GTE the following protection class IP 54 is valid

- for the housing of motor and gearbox
- for the output shaft of the gearbox
- for the power and encoder connection on the motor at professional mounting.

The first reference number defines the degree of protection against contact and penetration of foreign bodies. The reference number 5 means

- Protection against penetration of dust (dust-proof)
- Complete contact protection.

The second characteristic numeral defines the degree of protection against water. The reference number 4 means

- Protection against splashed water.

Surface Protection

The gearboxes are surface-protected by the CitroX-method. The CitroX-method is an environmentally-sound, thermo-chemically diffusion-method, whereby wear behavior, corrosion-resistance and fatigue resistance of the gearbox housing are improved.

Application Notes

5.1.2 Operating Mode S5 (Intermitted Operation)

Planetary gearboxes of GTE series are suitable for the operating mode S5 (intermitted operation with braking) according to EN 60034-1. The operation time should herewith not surpass 60%.

$$ED = \frac{T_A + T_B + T_{Br}}{T_s} \cdot 100\% \leq 60\%$$

Fig.5-2: Operation time for intermitted operation

A procedure during intermittent duty, which consists of an acceleration and a braking, is defined as a cycle.

The specified data of the gearboxes in the chapter "Technical Data" are valid up to 1,000 cycles per hour.

Are more than 1,000 cycles per hour during operation of the gearbox necessary, the technical data have to be reduced by a factor (see Fig. 5-3).

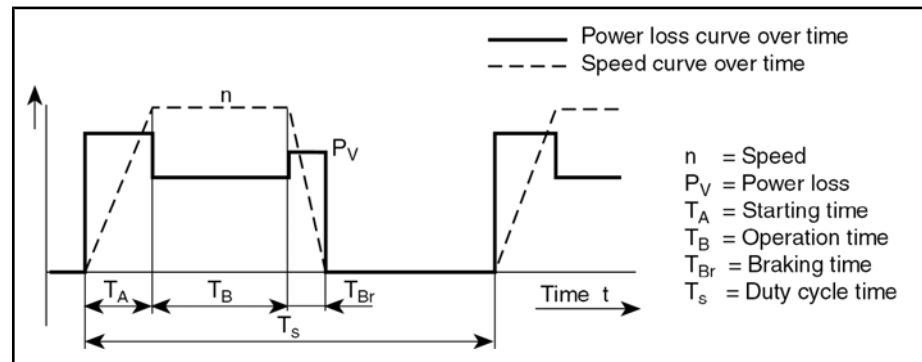

Fig.5-3: Operating mode S5 (intermittent duty with electronical braking)

Reduction at Higher Cycles

Are higher cycles than 1,000 cycles per hour needed, the following reduced technical data, regarding torque and power are valid.

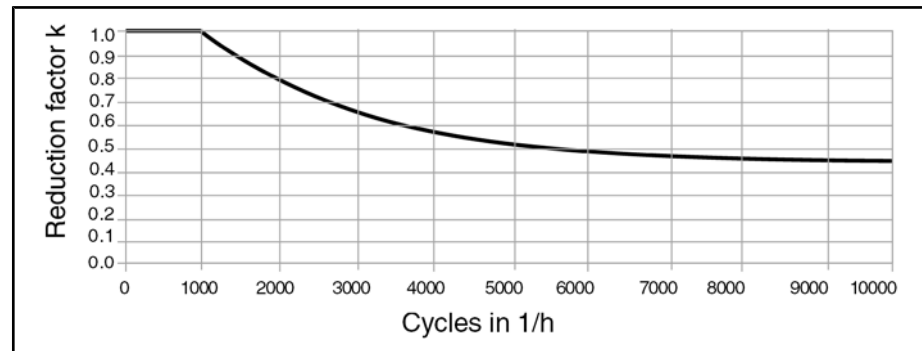

Fig.5-4: Reduction factor at higher cycles

5.1.3 Operating Mode S1 (Continuous Operation)

Planetary gearboxes GTE are suited for the operating mode S1 according to EN 60034-1.

5.2 Operating Gearboxes or Motor-Gearbox Combinations in Hazardous Areas (ATEX)

For more information about ATEX directive and combining a GTE planetary gearbox with an explosion-proof motor (e.g. MSK Motor acc. to ATEX standard), please contact your responsible sales office.



Servo planetary gearboxes acc. to ATEX for mounting on Ex-motors, like MSK motors acc to ATEX Standard are **no** products of Rexroth and will not be offered or delivered neither separately nor mounted.

Basically, assembly of ATEX gearboxes on Rexroth motors is possible. Therefore, obtain the gearboxes directly from the supplier and assemble them by yourself.

We recommend the following manufacturer for the ATEX-gearboxes:

Neugart GmbH
 Keltenstraße 16
 77971 Kippenheim, Germany
 Phone +49 (0) 78 25 – 847-0
 Fax +49 (0) 78 25 – 847-2999
 Email: info@neugart.de
 Internet: http://www.neugart.de

5.3 Mechanical Features

Construction, installation position Rexroth planetary gearboxes GTE are manufactured in the construction B05 for flange mounting. The installation positions can be done as described in the following table according to EN 60034-7:1996-06.

Gearbox Construction	Permissible Installation Positions according to EN 60034-7:1996-06	Important Installation Note
B05		Vertical mounting position IM V3 . When installing IM V3 (vertically, output shaft upwards) dam of liquid on the drive shaft has to be avoided, as liquid can penetrate into the gearbox over a longer period of time.

Fig.5-5: Permittable construction

Output Shaft The output shaft of the planetary gearboxes is available in the following variants:

- **Smooth output shaft (standard)**

For a plain non-positive shaft-hub connection.

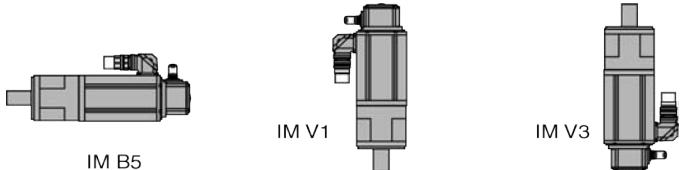
Therewith, a higher smooth running and a free of clearance connection between shaft and hub.



We recommend to use output shafts with non-positive shaft-hub connections.

or

- **Output shaft with keyway according to DIN 6885-1:1968-08**

For a form-fitting shaft-hub connection.

This connection mode is suitable for absorption of direction-constant speed at low demand. It makes an additional axial safety of the hub necessary. Therefore, the frontal of the gearbox output shaft is provided with a centering hole with a thread (see dimension sheet).

Application Notes

Shaft Load To check the shaft load, the axial and radial shaft load have to be checked separately:

The **radial shaft load** radial shaft load with subject to

- the point of application of force and
- the middle speed

take from the diagrams of chapter 6.2 "Permittable Shaft Load". For the rated bearing lifetime were 30,000 operation hours taken as basis (bearing calculation according to DIN ISO 281:1993-01).

The **axial shaft load** is also described in the chapter 6.2 "Permittable Shaft Load".

Assembly of Output Elements

The output shaft of the GTE-gearboxes is fitted with a massive shaft shoulder, which is well-suited for the support of axial forces, especially at key connections.

The according tightening torque (T_A), resp. preliminary-tension forces (F_V), for mounting the output unit have to be taken from the following table.

Size (one-stage & two-stage)					
	GTE040	GTE060	GTE080	GTE120	GTE160
Thread	M3	M5	M6	M10	M16
T_A [Nm]	1.2	5.5	9.5	46	195
F_V [kN]	2.1	6.5	9.0	25	70

Fig.5-6: Tightening torque, resp. preload at mounting the drive units

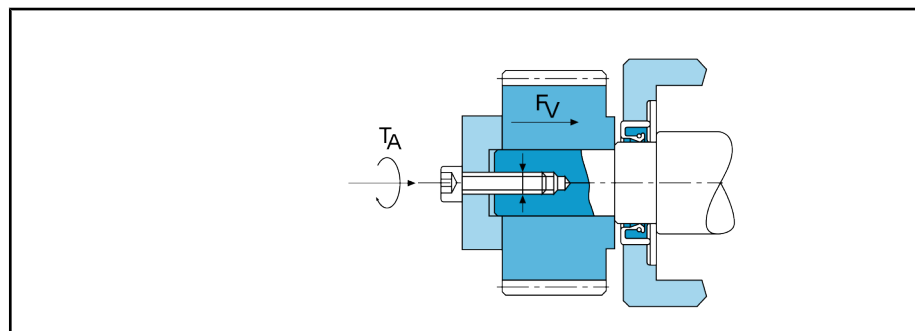

T_A Tightening torque
 F_V Preload

Fig.5-7: Output shaft

5.4 Combination Possibilities of GTE Planetary Gearboxes with Motors

The following table shows the combination possibilities of GTE planetary gearboxes with motors.



For more information about ATEX directive and combining a GTE planetary gearbox with an explosion-proof motor (e.g. MSK Motor acc. to ATEX standard), please contact your responsible sales office.

Possible motor/gearbox combination with GTE planetary gearboxes

Planetary Gearboxes	Motor type		
	MSM	MSK	KSM
GTE040	MSM019A	Not possible	Not possible
	MSM019B		
	MSM020B		
GTE060	MSM030B	MSK030	Not possible
	MSM031B		
GTE080	MSM030C	MSK030	KSM041
	MSM031C		
	MSM040B	MSK040	
	MSM041B		
GTE120	MSM040B MSM041B	MSK040	KSM041 KSM061
		MSK050	
		MSK060	
GTE160	Not possible	MSK061	KSM061 KSM071 KSM076
		MSK070	
		MSK071	
		MSK075	
		MSK076	
		MSK100	

Fig. 5-8: Possible motor/gearbox combination with GTE planetary gearboxes



To mount the GTE planetary gearboxes on motors, the motors must have a smooth drive shaft.

6 Technical Data

6.1 Technical Data for Intermittent and Continuous Operation

Due to technical development of the GTE gearboxes, the technical data regarding permitted torques, torsional play and torsional strength could be improved.



These "new" technical data are valid for GTE gearboxes from manufacturing date **09W01** and are given in the following table.

To estimate the thermal permitted area of the gearboxes, a detailed display format of the permitted nominal speed was chosen.



You will find the previous technical data in the chapter "Appendix".

Technical data for intermittent and continuous operation

Description	Symbol		Transmission ratio	GTE040	GTE060	GTE080	GTE120	GTE160
Max. initial speed ⁷⁾ min ⁻¹	n _{in, max}	one-stage	i=3	18,000	13,000	7,000	6,500	6,500
			i=4	18,000	13,000	7,000	6,500	6,500
			i=5	18,000	13,000	7,000	6,500	6,500
			i=8	18,000	13,000	7,000	6,500	6,500
		two-stage	i=12	18,000	13,000	7,000	6,500	6,500
			i=20	18,000	13,000	7,000	6,500	6,500
Max. initial torque ^{1) 9) 10) 11)} Nm	M _{in, max}	one-stage	i=3	5.8	15	45.3	61.3	213.3
			i=4	6	15.25	46	62	180
			i=5	4.4	12.8	35.2	62.4	144
			i=8	1.3	3.6	10	24	90
		two-stage	i=12	2.7	5.8	16	34.7	106.7
			i=20	1.6	3.5	9.6	20.8	64
Max. output speed ⁷⁾ min ⁻¹	n _{out, max}	one-stage	i=3	6,000	4,333	2,333	2,166	2,166
			i=4	4,500	3,250	1,750	1,625	1,625
			i=5	3,600	2,600	1,400	1,300	1,300
			i=8	2,250	1,625	875	812.5	812.5
		two-stage	i=12	1,500	1,083	583	541.7	541.7
			i=20	900	650	350	325	325
			i=40	450	325	175	162.5	162.5

Technical Data

Description	Symbol		Transmission ratio	GTE040	GTE060	GTE080	GTE120	GTE160
Max. output torque ^{1) 9) 10) 11)} Nm	$M_{out, max}$	one-stage	i=3	17.6	45	136	184	640
			i=4	24	61	184	248	720
			i=5	22	64	176	312	720
			i=8	10	29	80	192	720
		two-stage	i=12	32	70	192	416	1,280
			i=20	32	70	192	416	1,280
		i=40	29	64	176	368	1,120	
Nominal initial speed at 50% $M_{out, nenn}$ ^{7) 12)} min^{-1}	$n_{in, nenn}$	one-stage	i=3	5,000	4,500	3,900	3,500	1,700
			i=4	5,000	4,500	3,650	3,500	1,700
			i=5	5,000	4,500	4,000	3,500	2,000
			i=8	5,000	4,500	4,000	3,500	2,900
		two-stage	i=12	5,000	4,500	4,000	3,500	1,950
			i=20	5,000	4,500	4,000	3,500	2,700
		i=40	5,000	4,500	4,000	3,500	3,000	
Nominal initial speed at 100% $M_{out, nenn}$ ^{7) 12)} min^{-1}	$n_{in, nenn}$	one-stage	i=3	5,000	4,450	2,400	2,500	1,000
			i=4	5,000	4,400	2,150	2,250	1,000
			i=5	5,000	4,500	2,650	2,250	1,150
			i=8	5,000	4,500	4,000	3,500	1,750
		two-stage	i=12	5,000	4,500	3,450	2,500	1,050
			i=20	5,000	4,500	4,000	3,500	1,500
		i=40	5,000	4,500	4,000	3,500	2,950	
Nominal initial torque ^{1) 9) 10) 11)} Nm	$M_{in, nenn}$	one-stage	i=3	3.7	9.3	28.3	38.3	133.3
			i=4	3.8	9.5	28.8	38.8	112.5
			i=5	2.8	8	22	39	90
			i=8	0.8	2.3	6.3	15	56.3
		two-stage	i=12	1.7	3.7	10	21.7	66.7
			i=20	1	2.2	6	13	40
		i=40	0.5	1	2.8	5.8	17.5	
Nominal initial speed at 50% ^{7) 12)} $M_{out, nenn}$ min^{-1}	$n_{out, nenn}$	one-stage	i=3	1,666.7	1,500	1,300	1,166.7	566.7
			i=4	1,250	1,125	912.5	875	425
			i=5	1,000	900	800	700	400
			i=8	625	562.5	500	437.5	362.5
		two-stage	i=12	416.7	375	333.3	291.7	162.5
			i=20	250	225	200	175	135
		i=40	125	112.5	100	87.5	75	

Technical Data

Description	Symbol		Transmission ratio	GTE040	GTE060	GTE080	GTE120	GTE160
Nominal initial speed at 100% ^{7) 12)} $M_{out,nenn}$ min^{-1}	$n_{out,nenn}$	one-stage	i=3	1,666.7	1,483.3	800	833.3	333.3
			i=4	1,250	1,100	537.5	562.5	250
			i=5	1,000	900	530	450	230
			i=8	625	562.5	500	437.5	218.8
		two-stage	i=12	416.7	375	287.5	208.3	87.5
			i=20	250	225	200	175	75
			i=40	125	112.5	100	87.5	73.8
Nominal output torque ^{1) 9) 10)} Nm	$M_{out,nenn}$	one-stage	i=3	11	28	85	115	400
			i=4	15	38	115	155	450
			i=5	14	40	110	195	450
			i=8	6	18	50	120	450
		two-stage	i=12	20	44	120	260	800
			i=20	20	44	120	260	800
			i=40	18	40	110	230	700
Mass moment of inertia ¹³⁾ $kg\ cm^2$	J	one-stage	i=3	0.031	0.135	0.77	2.63	12.14
			i=4	0.022	0.093	0.52	1.79	7.78
			i=5	0.019	0.078	0.45	1.53	6.07
			i=8	0.017	0.065	0.39	1.32	4.63
		two-stage	i=12	0.029	0.127	0.72	2.56	12.37
			i=20	0.019	0.075	0.44	1.50	6.65
			i=40	0.016	0.064	0.39	1.30	5.28
Torsional play ¹⁴⁾ arcmin	$\Delta\phi$	one-stage		<24	<16	<9	<8	<6
		two-stage		<28	<20	<14	<12	<10
Torsional strength ¹⁵⁾ Nm/arcmin	D	one-stage		1.0	2.3	6	12	38
		two-stage		1.1	2.5	6.5	13	41
Efficiency ⁶⁾ %	η	one-stage		96				
		two-stage		94				
Lifetime H	L_h			30,000				
Lubrication				Life lubrication				
Permitted ambient temperature °C	T_{Um}			0 ... +40°C				
Permitted gearbox housing temperature ³⁾ °C	T_G			-25°C ... +90°C				

Technical Data

Description	Symbol		Trans- mission ratio	GTE040	GTE060	GTE080	GTE120	GTE160
Noise level ⁴⁾ dB(A)	Lp			58	58	60	65	70
Degree of protection				IP54				
Weight kg	M	one-stage		0.35	0.9	2.1	6.0	18
		two-stage		0.45	1.1	2.6	8.0	22

- 1) these values refer to a speed of the output shaft of $n_{out} = 100 \text{ min}^{-1}$ on duty cycle $K_A = 1$ and S1-mode for electrical machines and $T=30^\circ\text{C}$.
- 2) referring to the middle of the output shaft
- 3) referring to the middle of the housing surface
- 4) sound pressure level in 1m distance; measured on drive speed of $n_{in} = 3,000 \text{ min}^{-1}$ without load; $i=5$
- 5) allowed 1,000 times
- 6) depends on ratio $n_{out} = 100 \text{ min}^{-1}$
- 7) allowed operating temperatures must be kept
- 8) ratios ($i = n_{out} / n_{in}$)
- 9) depends on the motor shaft diameter
- 10) with key: for tumscnt load
- 11) permitted for 30,000 revolutions at the output shaft: refer to chapter 6.2 Maximum transferable output torque
- 12) For definition see chapter 6.3 Thermal specifications for S1 operation
- 13) the moment of inertia relates to the input shaft and to standard motor shaft diameter
- 14) with regard to the gearbox output at 3% nominal output torque of the gearbox and locked gearbox input side
- 15) torsional rigidity of the gearbox with regard to the gearbox output side at locked gearbox input side

Fig.6-1: *Ratio-dependent data*



The GTE planetary gearboxes are designed for the indicated specified permitted technical data. With regard to the operating safety it is only allowed to use the gearboxes in this case under view of all operating factors. Any sort of overload of the gearbox is classified as inappropriate use. Any changes on the gearbox exclude all liability on the part of Bosch Rexroth for any damages.

6.2 Maximum Transferable Output Torque

At $M_{out, nenn}$, Bosch Rexroth's planetary gearboxes are designed for high-cycle operation, in other words, if the application torques are always less than the nominal torque, no recalculation is necessary. However, it is possible to transfer higher application torques in the case of short torque peaks or long periods of intermittent duty. The following figure serves as guideline:

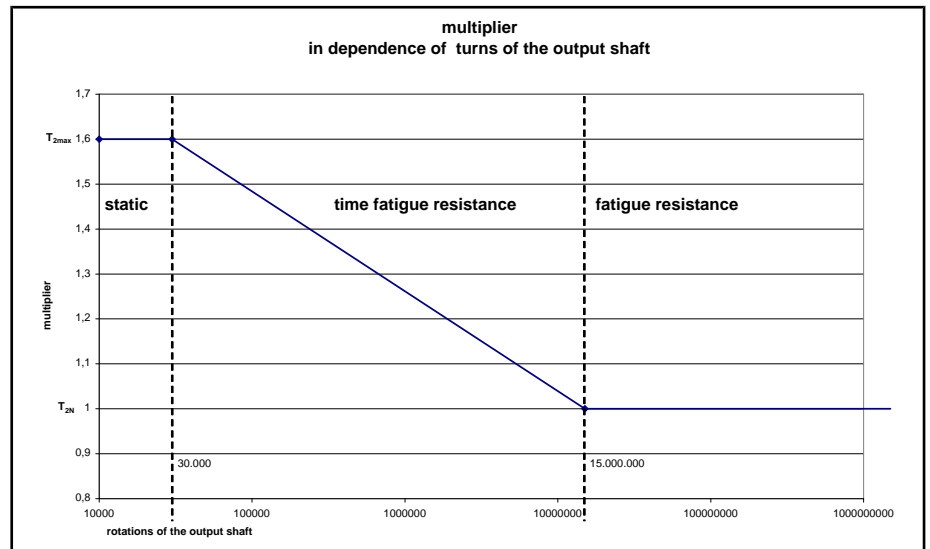

Fig. 6-2: Increase factor depending on the number of rotations of the output shaft

The maximum application torque must not exceed $1.6 \times M_{out, nenn}$. The number of rotations of the output shaft at the max. torque has to be calculated. If the number of rotations is larger than 15.000.000, the gearbox may only be subjected to the nominal torque of the gearbox. If the number of rotations is smaller than 15.000.000, the increase factor can be calculated by means of the following formula:

$$f = -0.1039 \cdot \ln \left(\frac{10^5}{30,000} \cdot \text{revolutions} \right) + 2.79$$

If $f > 1.6$, f is set to 1.6

If $f > 1.0$, f is set to 1.0

The maximum transferable moment $M_{out, max}$ of the gearbox is then calculated by means of $M_{out, max} = f \cdot M_{out, nenn}$.

the maximum application torque must not exceed the calculated maximum output torque of the gearbox.

$$M_{out, max} \leq M_{application}$$

6.3 Thermal Specifications for S1 Operation

Calculation of average speed:

$$n_m = \frac{n_1 * t_1 + \dots + n_x * t_x}{t_1 + \dots + t_x}$$

Assumed ambient conditions:

- Motor does not heat up the gearbox
- Plate size (square) = 2 x gearbox size
- Plate material: steel
- Convection is not impaired (no housing in the direct proximity of the gearbox)
- Ambient temperature: 30°C
- Plate connection on machine bed: one-sided (30°C)

In the case of a required **output torque of 100%**:

If n_m is smaller than the nominal initial speed at 100% load, the gearbox is thermally suitable.

In the case of a required **output torque of 50%**:

If n_m is smaller than the nominal initial speed at 50% load, the gearbox is thermally suitable.



If conditions are unfavorable, please reduce the speeds or consult Bosch Rexroth.

6.4 Technical Data at Increased Lifetime

The technical data is based on a calculated gearbox-lifetime of $L_h = 30,000$ h. If a gearbox-lifetime of more than 20,000h is required, the technical data, regarding torque and speed have to be reduced by the following diagram.

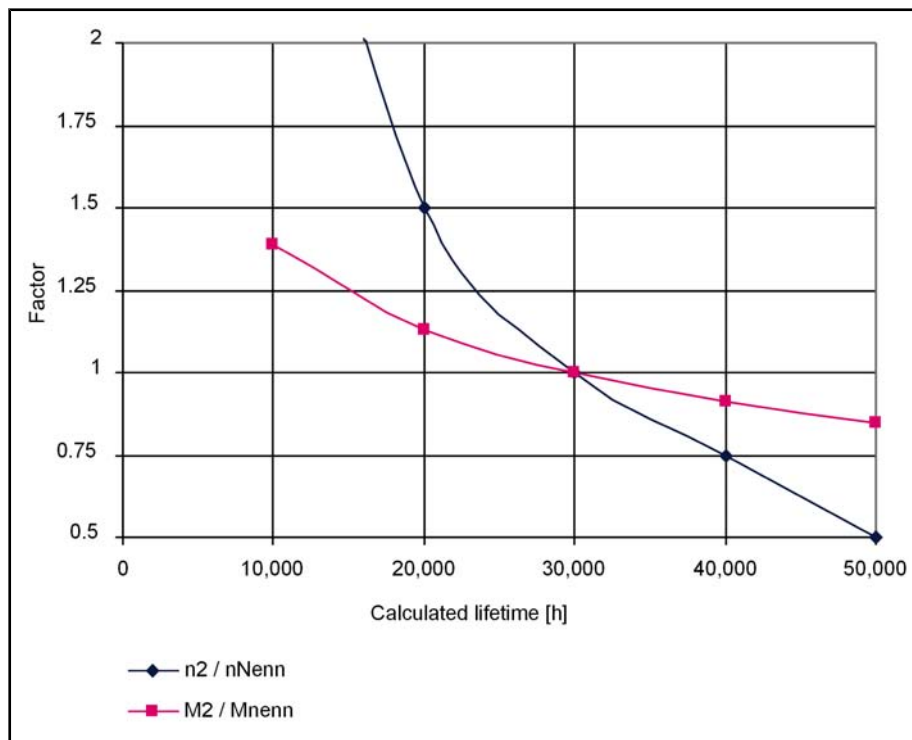

Fig. 6-3: Reduction of the technical data for increased lifetime



The permitted technical operating data may not be exceeded!

6.5 Limiting Temperature Curves to Determine Higher S1-Speed

Special applications (e.g. printing sector) require higher S1-speed than given in the technical data. The GTE gearboxes fulfill these requirements at an accordingly reduced output torque individually for every gearbox size and ratio. The following limiting temperature curves are the basis.

The values according to the diagram in Fig. 5-1 have to be reduced if the ambient temperature is higher than 30°C.



The determined limiting characteristic curves are related on an ambient temperature of 30°C at unhindered air circulation and fastening on the steel flange, which is more than twice as wide as the gearbox and has a temperature of 30°C.

Technical Data

⚠ CAUTION

Overload of the gearbox due to exceeding the permitted gearbox housing temperature of 90°C.

During operation of motor/gearbox combinations in the selected operating point, please make sure that the permitted gearbox housing temperature of 90°C is not exceeded to avoid a gearbox overload.

Depending from the gearbox or motor type, more or less heat is induced from the motor into the gearbox. For thermal inappropriate mounting it is recommended to check the permitted gearbox housing temperature after reaching the thermal steady-state.

GTE040: limiting temperature curves at $\Delta T = 60K$

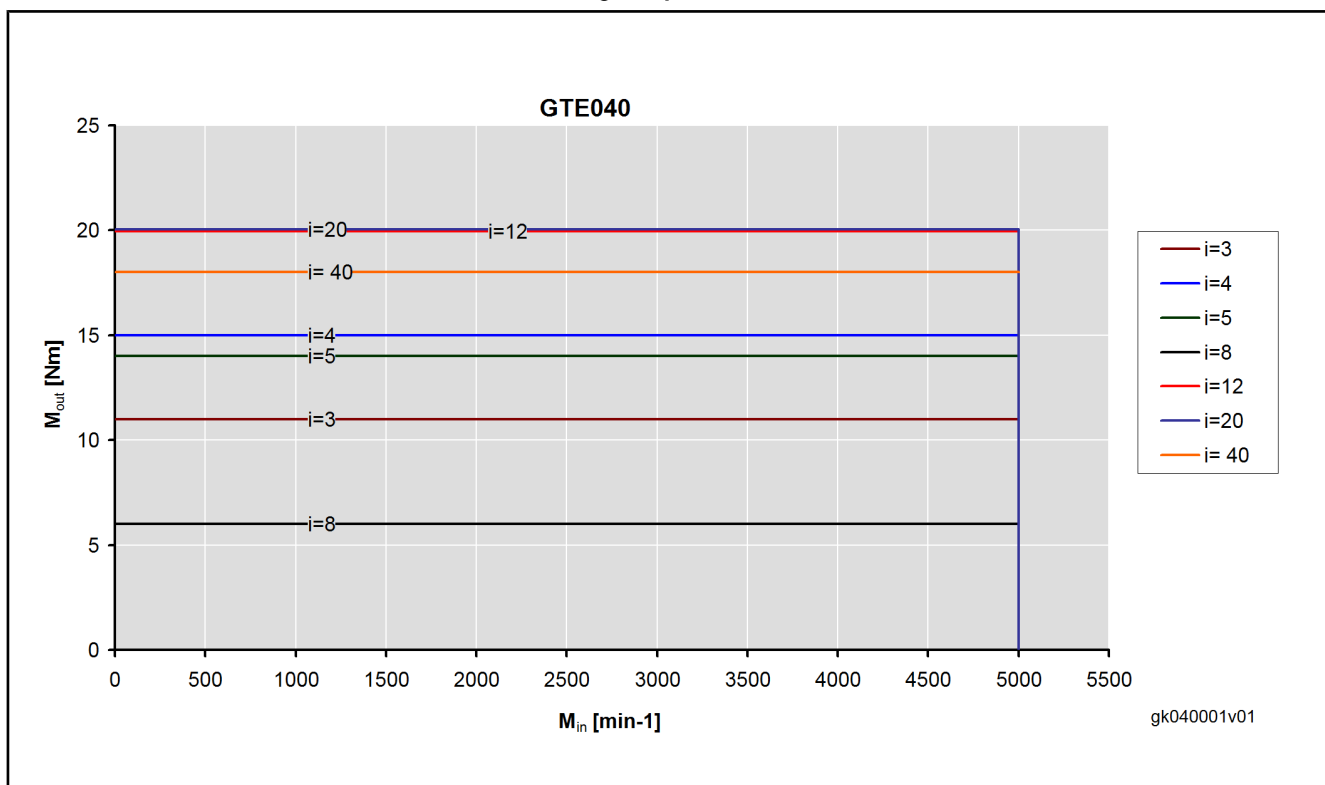

M_{out} Output torque

M_{in} Input speed

Fig.6-4: Ratio at limiting temperature curves GTE040

GTE060: limiting temperature curves at $\Delta T = 60K$

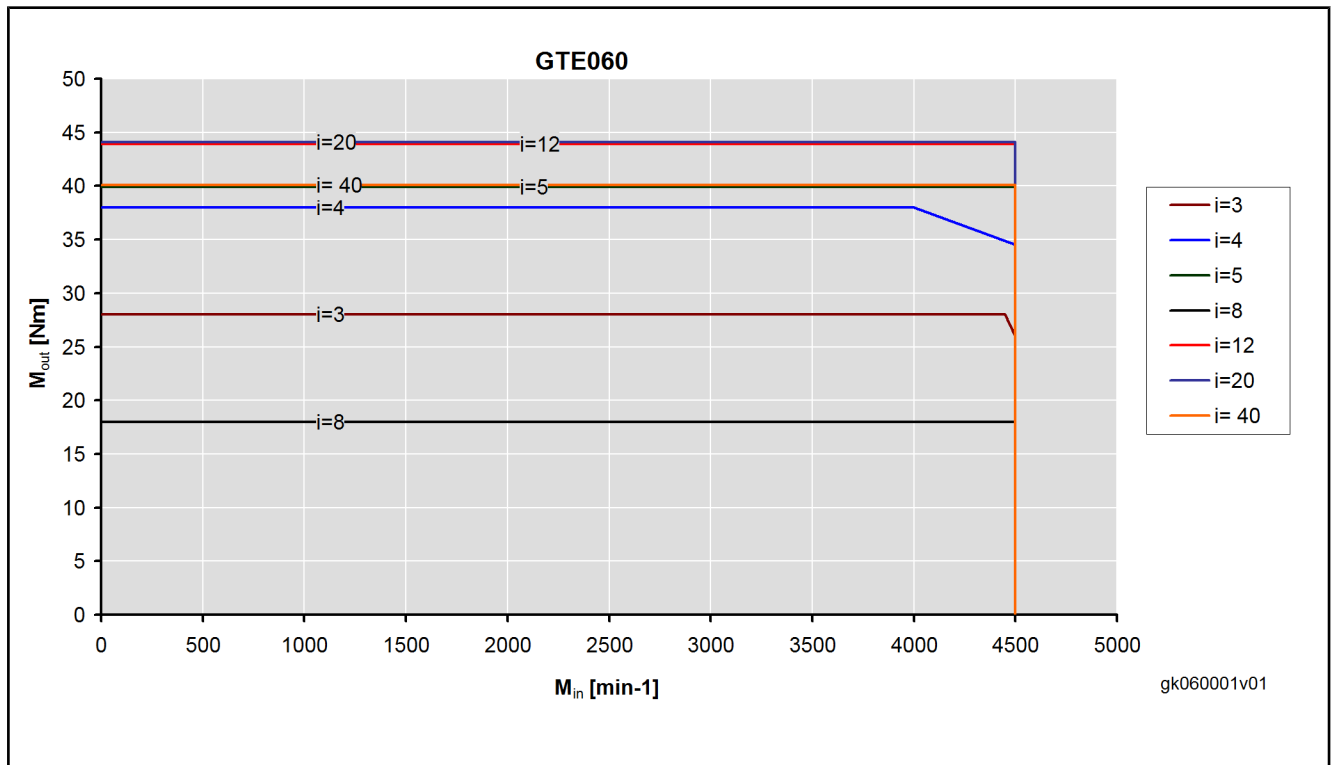

M_{out} Output torque

M_{in} Input speed

Fig. 6-5: Ratio at limiting temperature curves GTE060

Technical Data

GTE080: limiting temperature curves at $\Delta T = 60K$

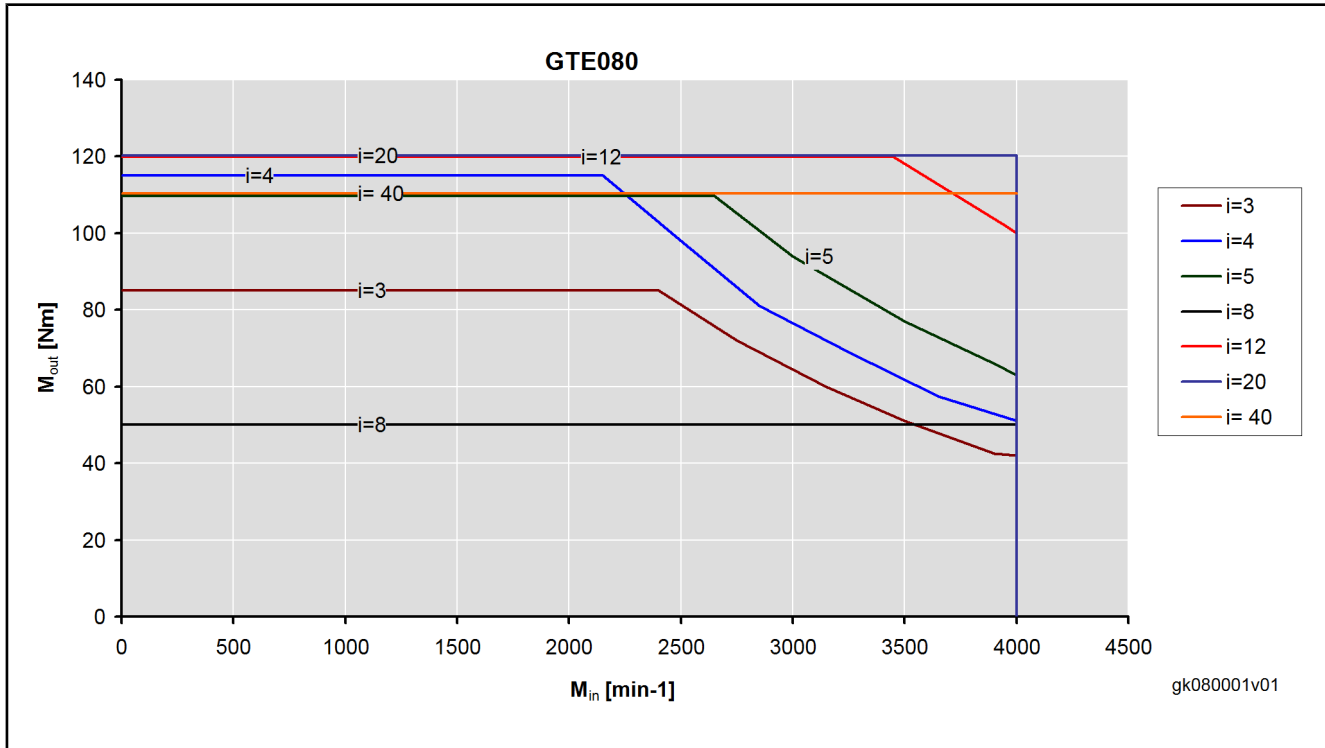

M_{out} Output torque

M_{in} Input speed

Fig.6-6: Ratio at limiting temperature curves GTE080

GTE120: limiting temperature curves at $\Delta T = 60K$

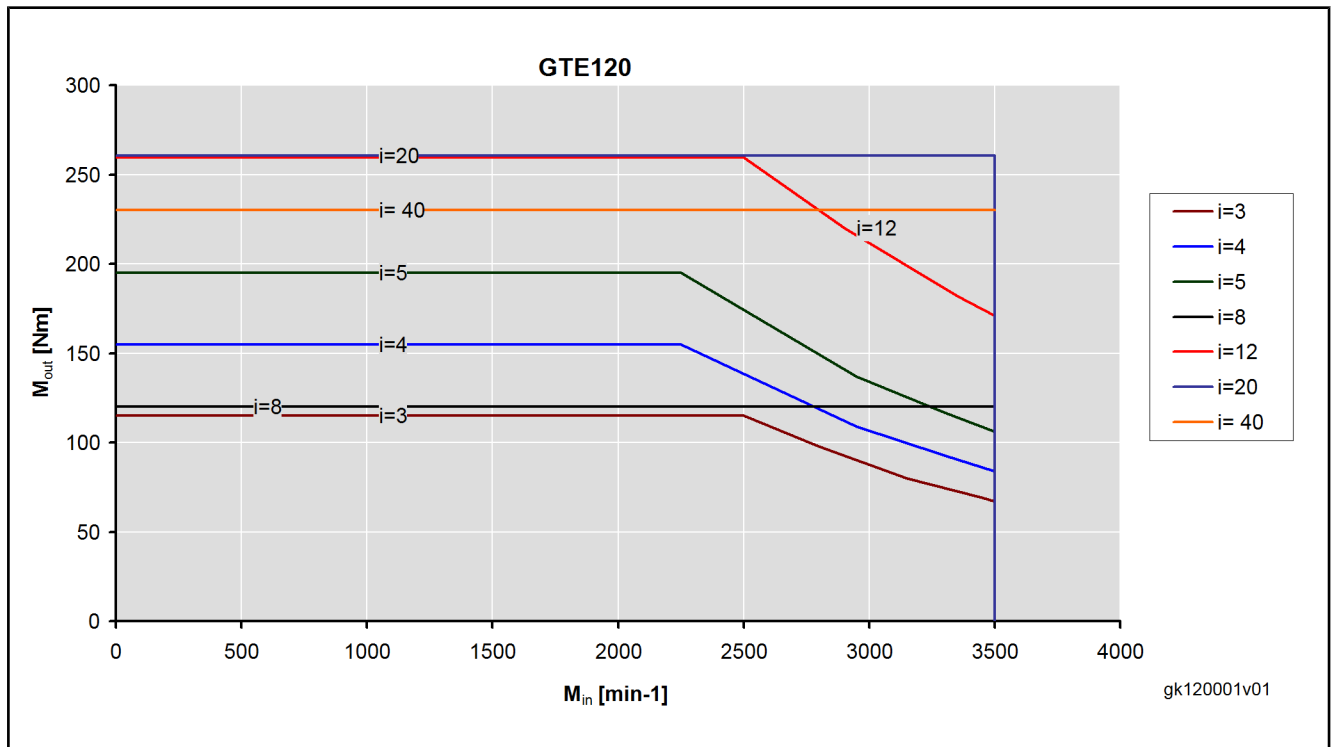

M_{out} Output torque

M_{in} Input speed

Fig. 6-7: Ratio at limiting temperature curves GTE120

Technical Data

GTE160: limiting temperature curves at $\Delta T = 60K$

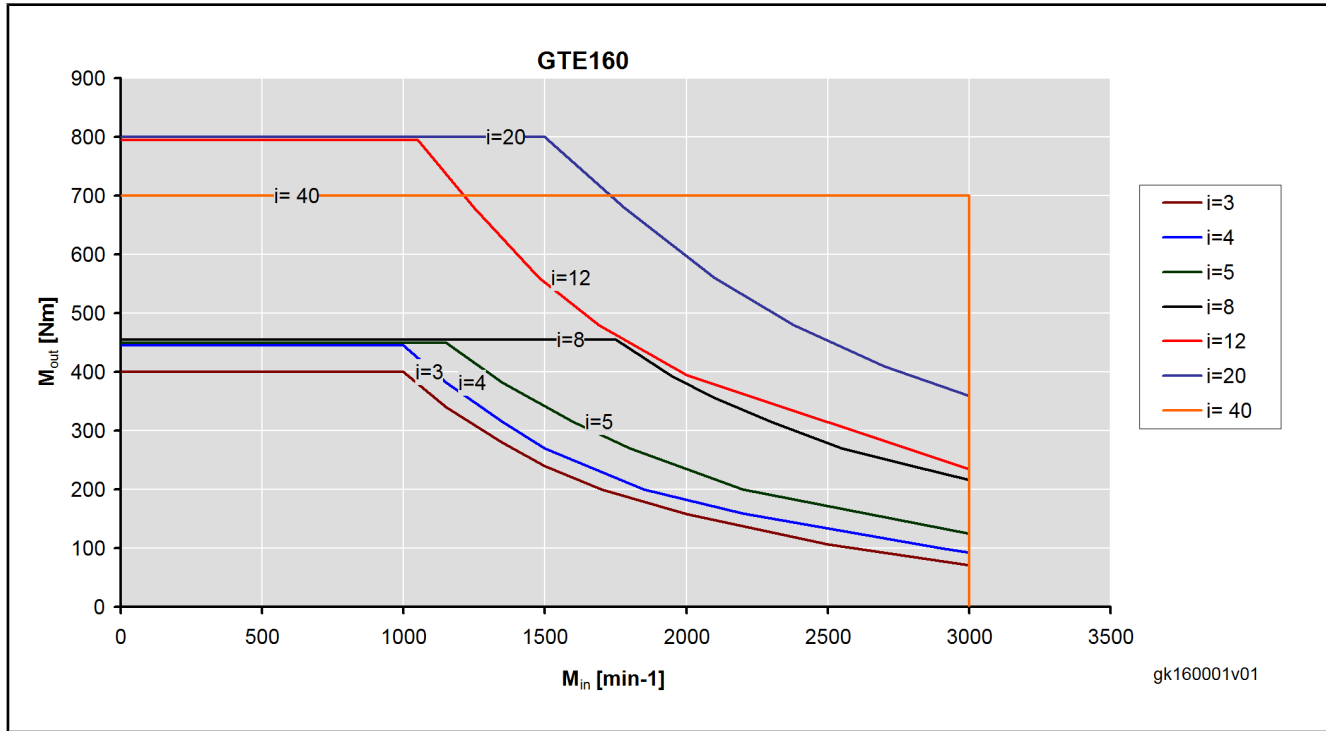

M_{out} Output torque
 M_{in} Input speed
 Fig.6-8: Ratio at limiting temperature curves GTE160

6.6 Permitted Shaft Load

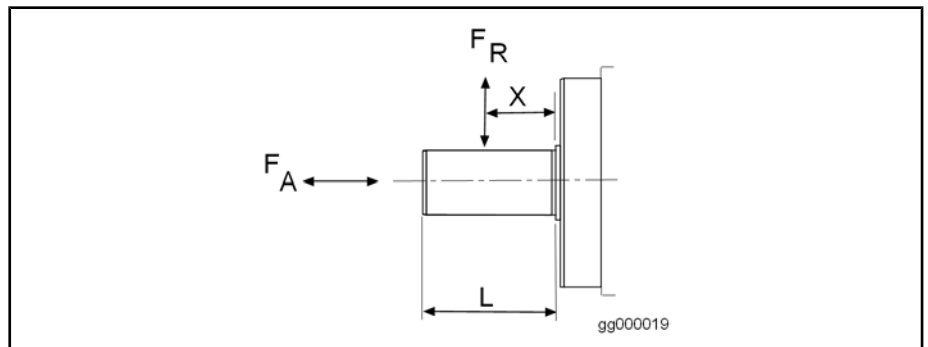

- F_A permissible axial force
 F_R permissible radial force
 X distance between shaft shoulder on the output shaft and point of application of the radial force
 n_{2m} average output speed of the cycle
Fig. 6-9: Permitted shaft load of GTE gearboxes

$$n_{2m} = \frac{n_{2a} \cdot t_a + n_{2b} \cdot t_b + \dots + n_{2n} \cdot t_n}{t_a + t_b + \dots + t_n}$$

Basis of design The GTE gearboxes are designed for a L_{10h} bearing life of 30,000 hours. For radial forces F_{Ref} , which lie over the value of the diagram, decreases the nominal bearing lifetime as follows:

$$L_{10k} = 30000 \cdot \left(\frac{F_R}{F_{Ref}} \right)^3$$

- F_R : permissible radial force
 F_{Ref} : necessary radial force

Technical Data

6.7 GTE040

Permitted Radial Force F_R :

Fig.6-10: Permitted Radial Force F_R GTE040

Permitted axial force $F_A < 160\text{N}$

F_A : permissible axial force

F_R : permissible radial force

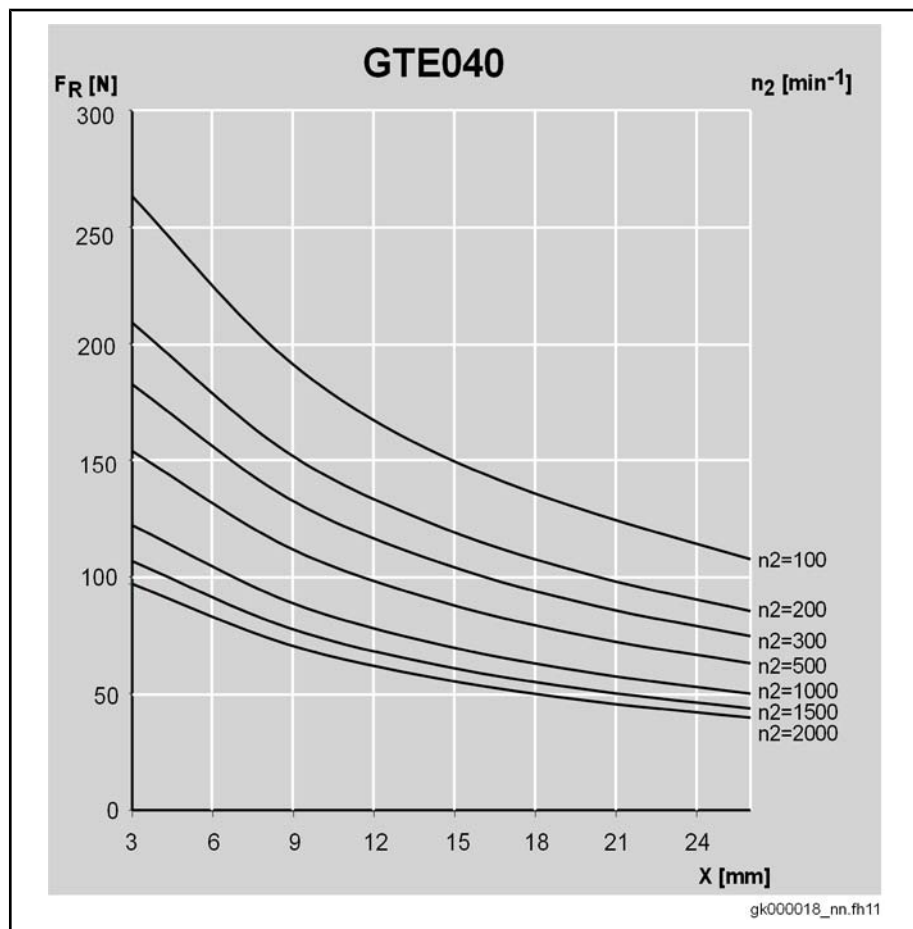
Do occur higher axial forces, the bearing lifetime for this use has to be calculated individually.

6.8 GTE060

Permitted Radial Force F_R :

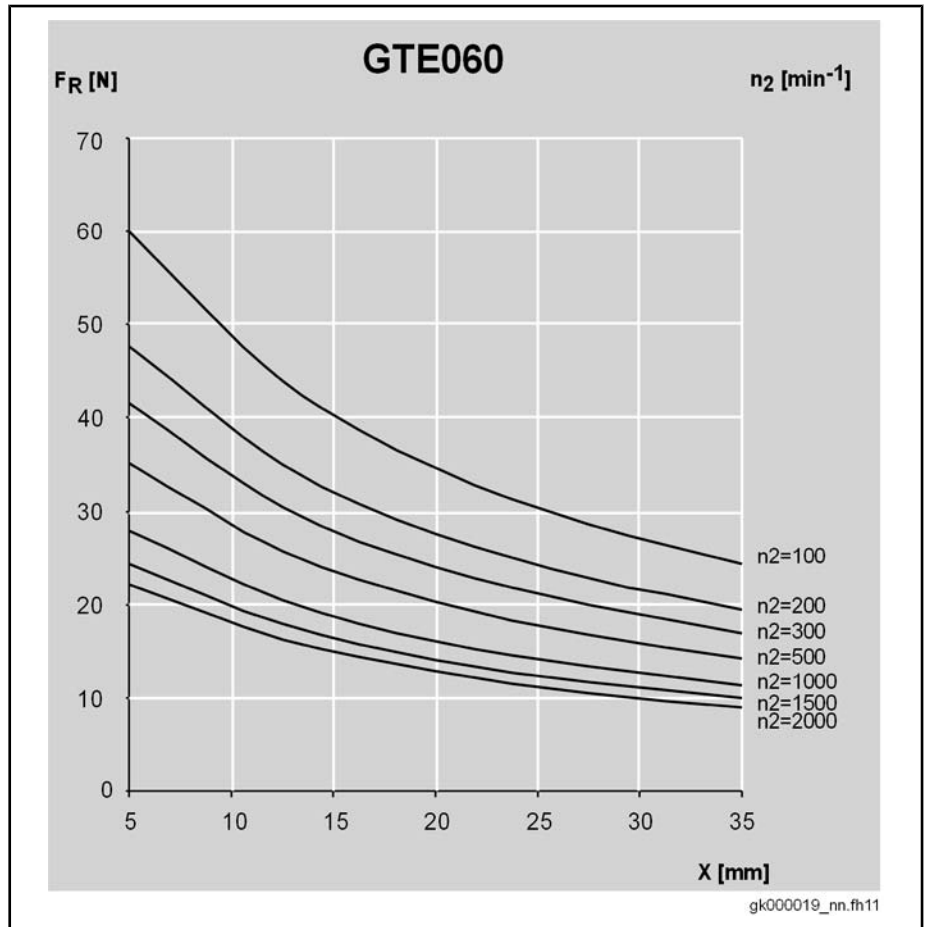

Fig. 6-11: Permitted Radial Force F_R GTE060

Permitted axial force $F_A < 450\text{N}$

F_A : permissible axial force

F_R : permissible radial force

Do occur higher axial forces, the bearing lifetime for this use has to be calculated individually.

Technical Data

6.9 GTE080

Permitted Radial Force F_R :

Fig.6-12: Permitted Radial Force F_R GTE080

Permitted axial force $F_A < 900\text{N}$

F_A : permissible axial force

F_R : permissible radial force

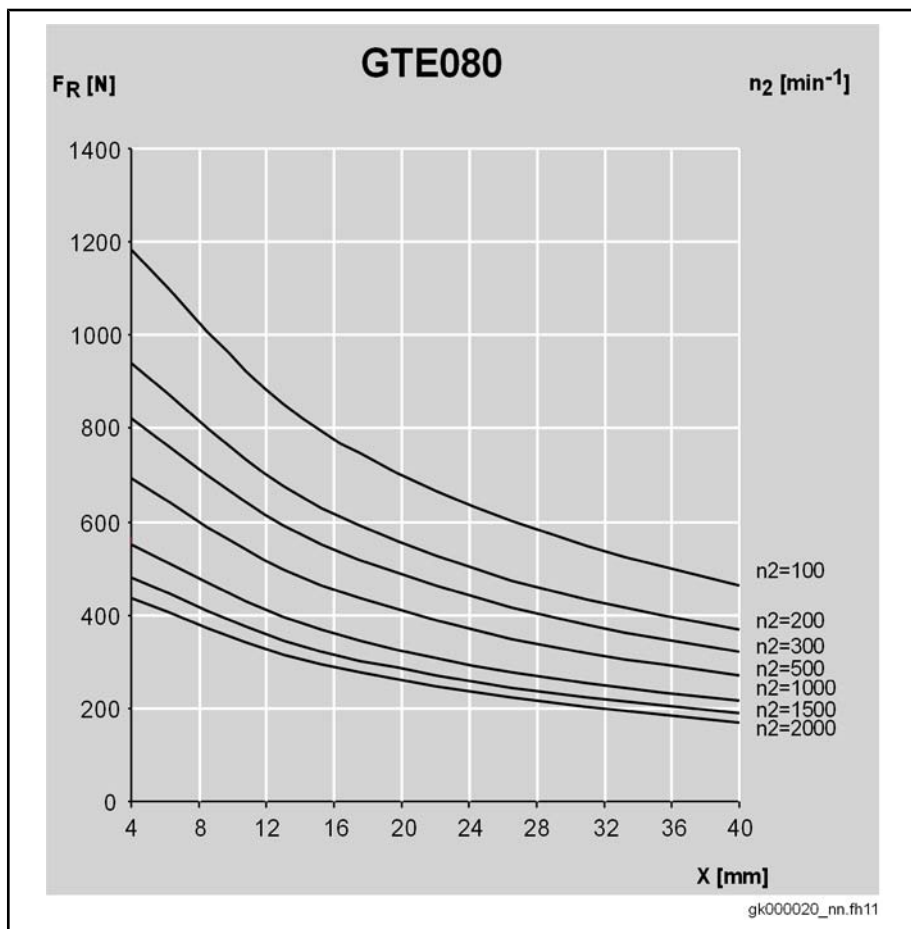
Do occur higher axial forces, the bearing lifetime for this use has to be calculated individually.

6.10 GTE120

Permitted Radial Force F_R :

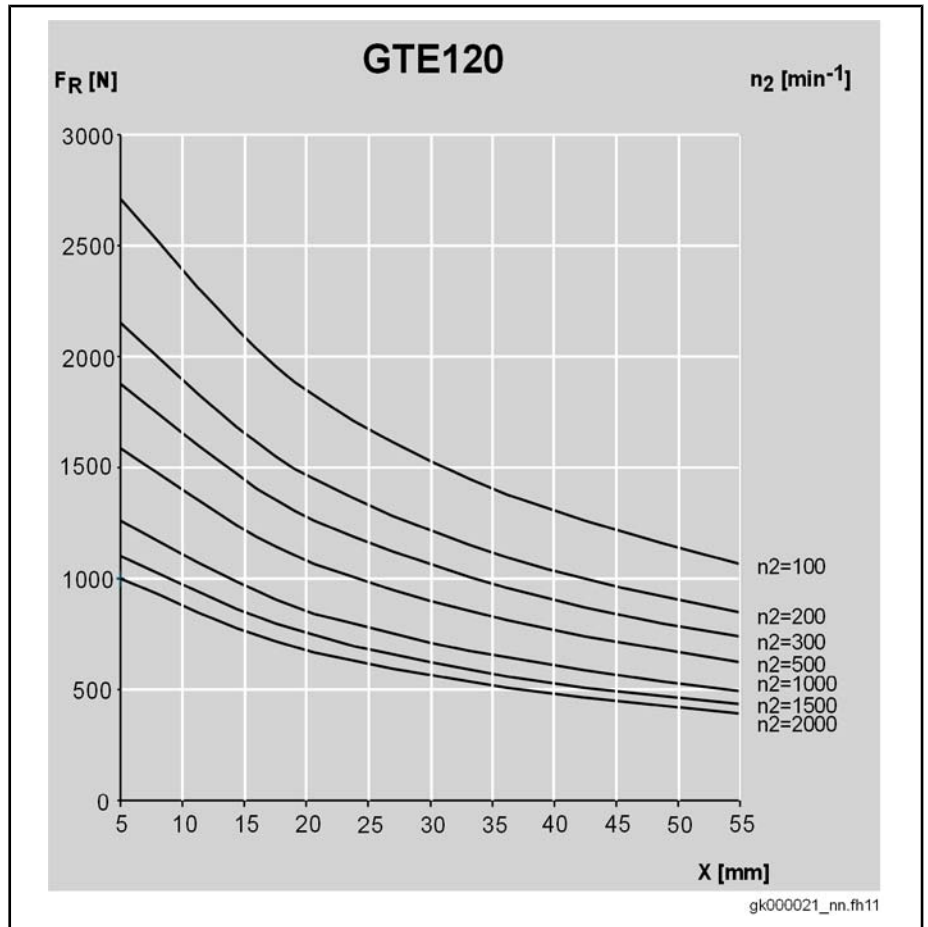

Fig. 6-13: Permitted Radial Force F_R GTE120

Permitted axial force $F_A < 2,100\text{N}$

F_A : permissible axial force

F_R : permissible radial force

Do occur higher axial forces, the bearing lifetime for this use has to be calculated individually.

Technical Data

6.11 GTE160

Permitted Radial Force F_R :

Fig.6-14: Permitted Radial Force F_R GTE160

Permitted axial force $F_A < 6,000\text{N}$

F_A : permissible axial force

F_R : permissible radial force

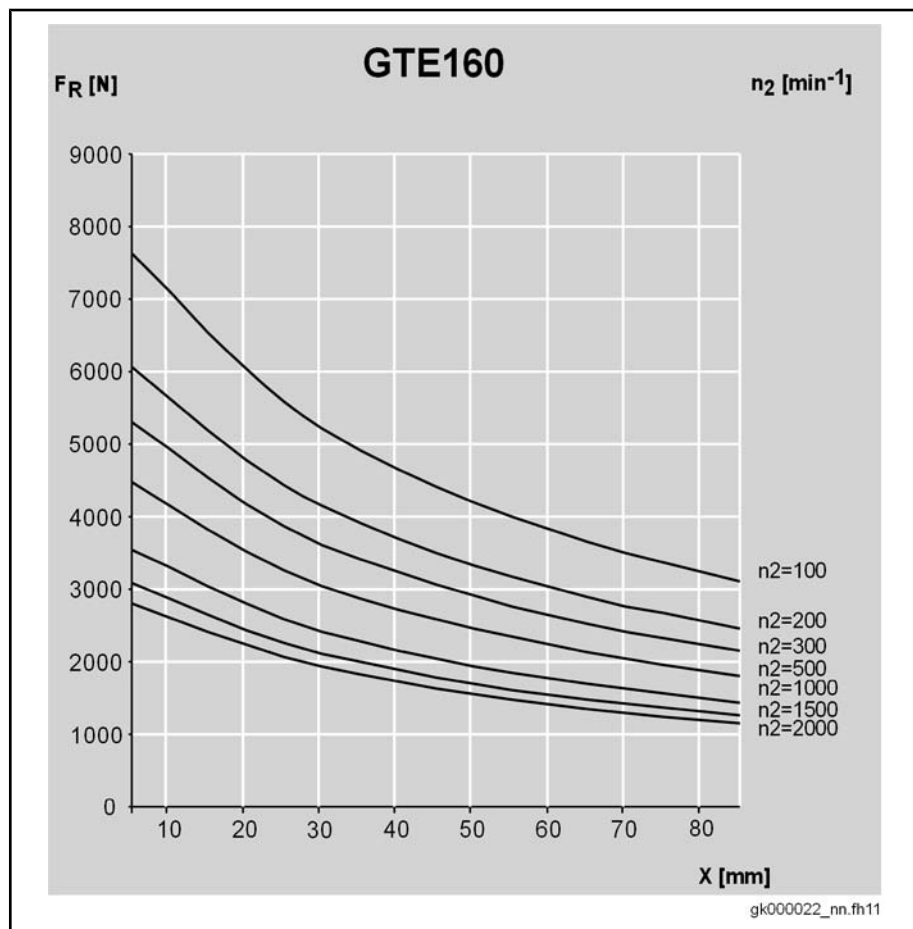
Do occur higher axial forces, the bearing lifetime for this use has to be calculated individually.

7 Specifications

7.1 GTE040

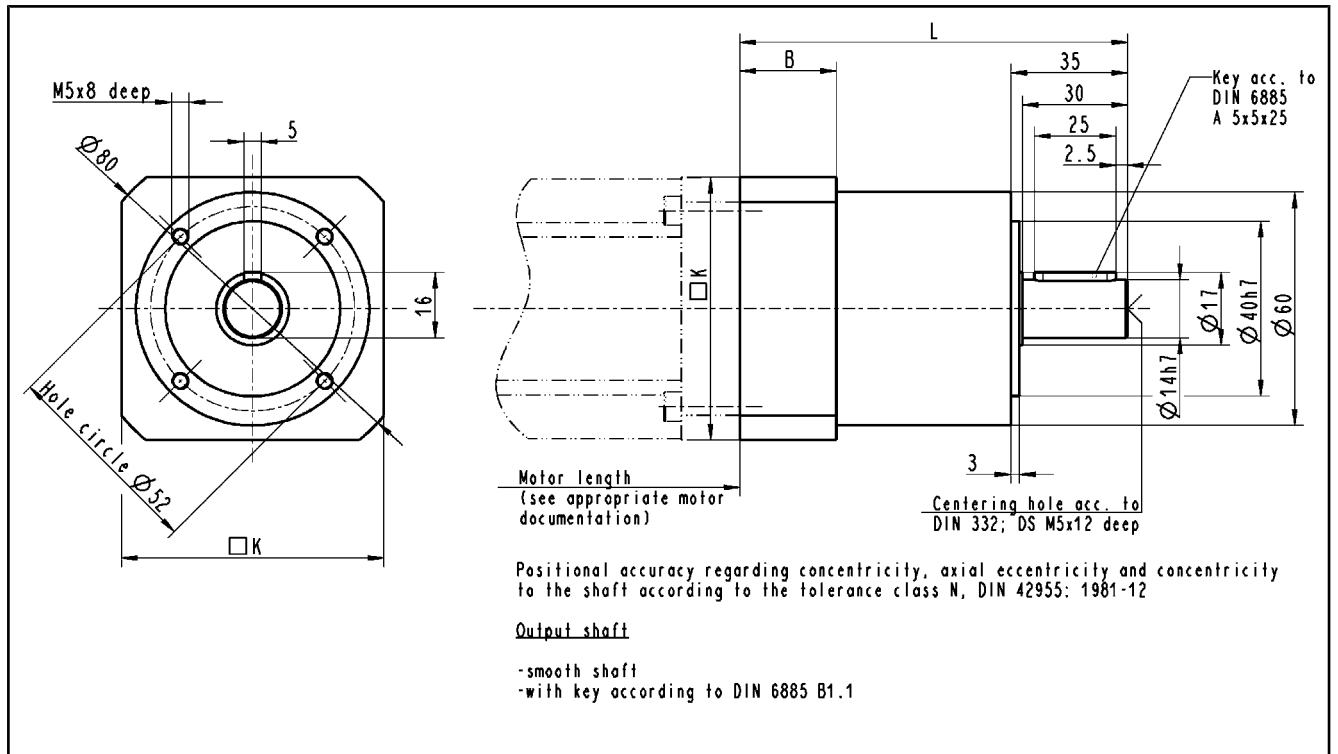

Fig.7-1: Dimensional details GTE040, one and two stage

Flanged motor type	One-stage		Two-stage		□ K ¹⁾
	L	B	L	B	
	[mm]	[mm]	[mm]	[mm]	[mm]
MSM020B	93.5	28.5	106.5	28.5	40
MSM019A, B	93.5	28.5	106.5	28.5	40

¹⁾ biggest flange size (motor/gearbox)

Fig.7-2: Dimensional details GTE040, one and two-stage

Specifications

7.2 GTE060

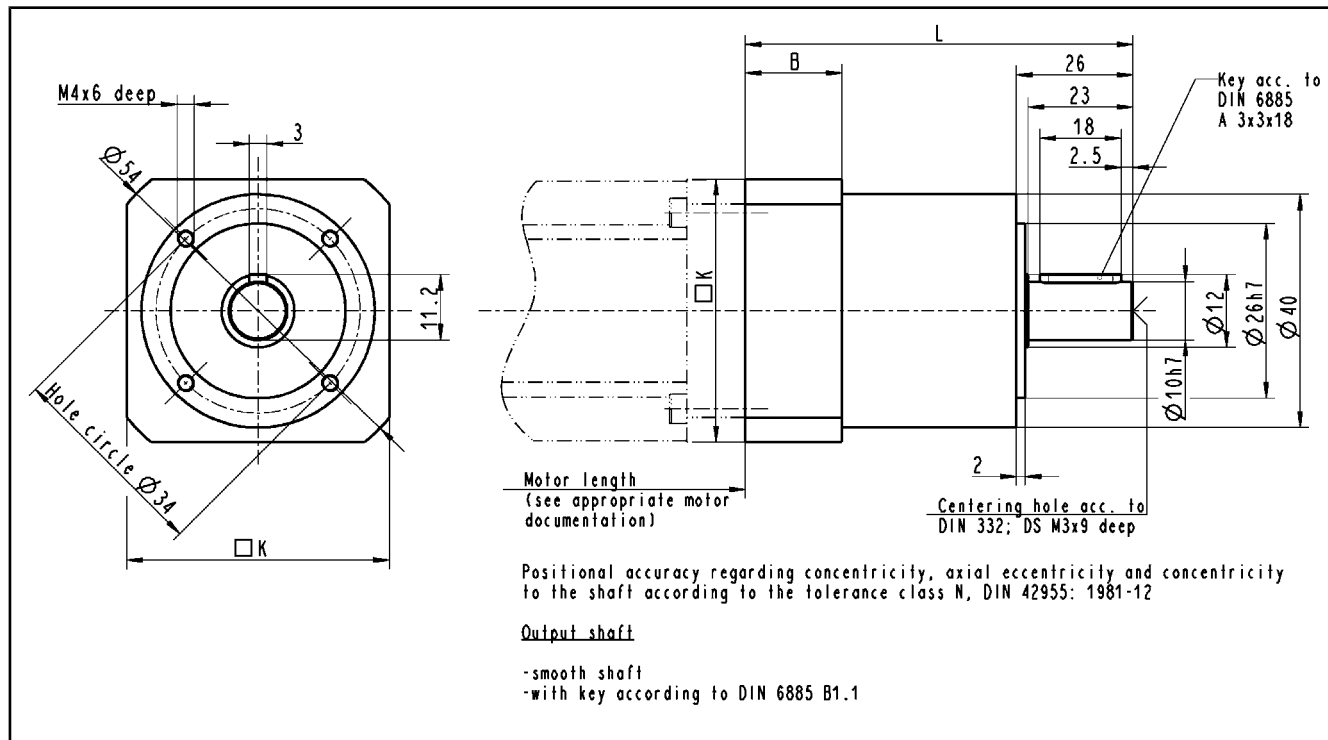

Fig.7-3: Dimensional details GTE060, one and two-stage

Flanged motor type	One-stage		Two-stage		$\square K^{1)}$
	L	B	L	B	
	[mm]	[mm]	[mm]	[mm]	[mm]
MSK030	106	24.5	118.5	24.5	60
MSM030B	113	31.2	125.5	31.2	60
MSM031B	113	31.2	125.5	31.2	60

¹⁾ biggest flange size (motor/gearbox)

Fig.7-4: Dimensional details GTE060, one and two-stage

7.3 GTE080

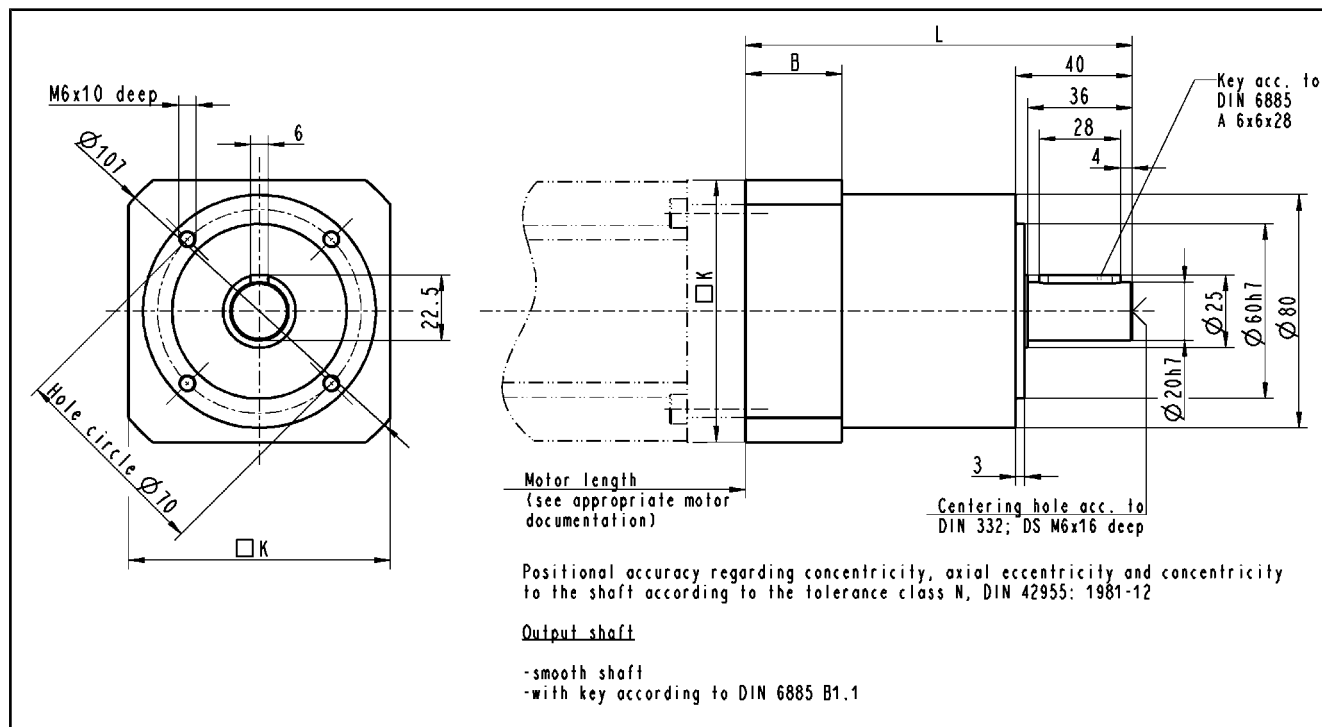

Fig.7-5: Dimensional details GTE080, one and two-stage

Flanged motor type	One-stage		Two-stage		$\square K^{1)}$ [mm]
	L [mm]	B [mm]	L [mm]	B [mm]	
MSK030	134	33.5	151	33.5	80
MSK040	134	33.5	151	33.5	90
MSM030C	134	33.5	151	33.5	80
MSM031C	134	33.5	151	33.5	80
MSM040B	138.5	38.5	156	38.5	90
MSM041B	138.5	38.5	156	38.5	90
KSM041	134	33.5	151	33.5	90

¹⁾ biggest flange size (motor/gearbox)

Fig.7-6: Dimensional details GTE080, one and two-stage

Specifications

7.4 GTE120

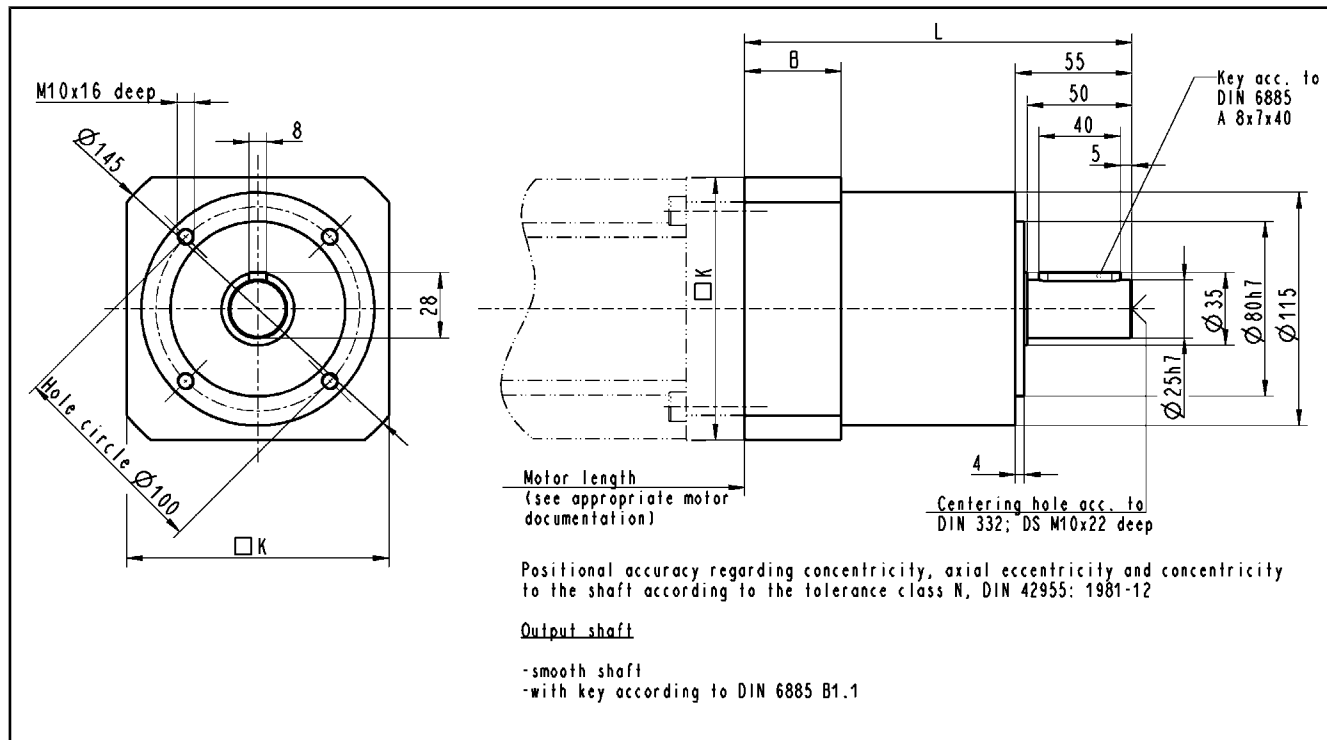

Fig.7-7: Dimensional details GTE120, one and two-stage

Flanged motor type	One-stage		Two-stage		$\square K^{1)}$
	L	B	L	B	
	[mm]	[mm]	[mm]	[mm]	[mm]
MSK040	176.5	47.5	203.5	47.5	115
MSK050	176.5	47.5	203.5	47.5	115
MSK060	186.5	57.5	-	-	115
MSK061	176.5	47.5	-	-	115
MSM040B	176.5	47.5	203.5	47.5	115
MSM041B	176.5	47.5	203.5	47.5	115
KSM041	176.5	47.5	203.5	47.5	115
KSM061	176.5	47.5	-	-	115

¹⁾ biggest flange size (motor/gearbox)

Fig.7-8: Dimensional details GTE120 one and two-stage

7.5 GTE160

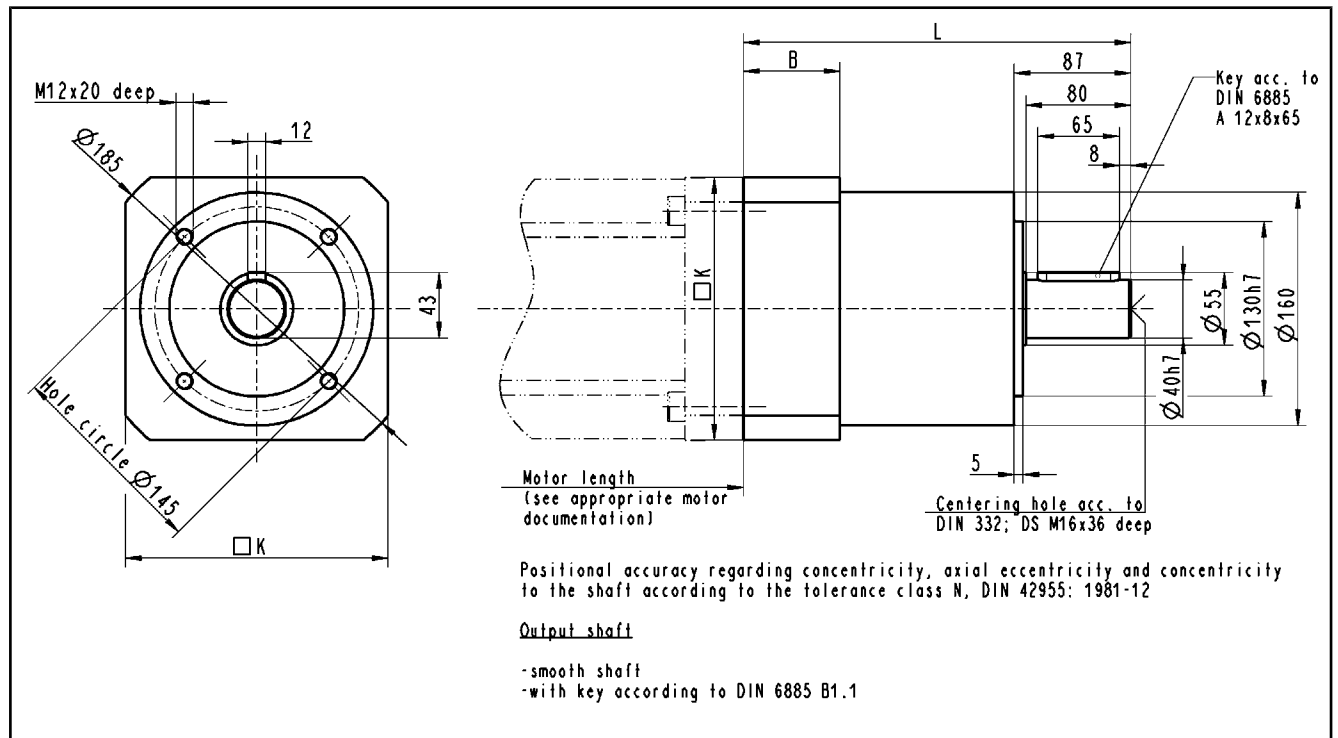

Fig.7-9: Dimensional details GTE160, one and two-stage

Flanged motor type	One-stage		Two-stage		□ K ¹⁾
	L	B	L	B	
	[mm]	[mm]	[mm]	[mm]	[mm]
MSK050	255.5	64.5	305	64.5	140
MSK060	255.5	64.5	305	64.5	140
MSK061	255.5	64.5	305	64.5	140
MSK070	263.5	72.5	313	72.5	140
MSK071	263.5	72.5	313	72.5	140
MSK075	263.5	72.5	313	72.5	140
MSK076	255.5	64.5	305	64.5	140
MSK100	265.5	74.5	-	-	190
KSM061	255.5	64.5	305	64.5	140
KSM071	263.5	72.5	313	72.5	140
KSM076	255.5	64.5	305	64.5	140

¹⁾ biggest flange size (motor/gearbox)

Fig.7-10: Dimensional details GTE160 one and two-stage

8 Type Codes

8.1 Notes on Connecting a Motor acc. to ATEX Standard

For more information about ATEX directive and combining a GTE planetary gearbox with an explosion-proof motor (e.g. MSK Motor acc. to ATEX standard), please contact your responsible sales office.



Servo planetary gearboxes acc. to ATEX for mounting on Ex-motors, like MSK motors acc to ATEX Standard are **no** products of Rexroth and will not be offered or delivered neither separately nor mounted.

Basically, assembly of ATEX gearboxes onto Rexroth motors is possible. The gearboxes have to be directly ordered at the supplier and mounted by yourself (for manufacturer recommendation refer to chapter 5.2 "Use of gearboxes or motor-gearbox combinations in hazardous areas (ATEX)").

8.2 Type Code GTE040

ZN-40019-040_NOR_N_EN_2008-09-19.fh11

Abbrev. column	1	2	3	4	5	6	7	8	9	0	1	2	3	4	5	6	7	8	9	0	1	2	3	4	5	6	7	8	9	0	1	2	3	4	5	6	7	8	9	0											
Example:	G	T	E	0	4	0	-	N	N	1	-	0	0	4	A	-	N	N	4	1																															

Product			
GTE	= GTE		
Size			
040	= 040		
Mounting position and operating mode			
Arbitrary	= NN		
Stages			
One-stage	= 1		
Two-stage	= 2		
Transmission ratio			
One-stage: 3 4 5 8	e.g., 4:1 ... = 004		
Two-stage: 12 20 40	e.g., 20:1 ... = 020		
Output shaft and reduced backlash			
With key	= A		
Plain	= B		
Designation of mounted motor			
Size	019A,B	020B	
Product	MSM	NN45	NN41

Fig. 8-1: Type Code GTE040

Type Codes

8.3 Type Code GTE060

ZN-40019-060_NOR_N_EN_2008-09-19.fh11

Abbrev. column →	1	2	3	4	5	6	7	8	9	0	1	2	3	4	5	6	7	8	9	0	1	2	3	4	5	6	7	8	9	0	1	2	3	4	5	6	7	8	9	0
Example:	G	T	E	0	6	0	-	N	N	1	-	0	0	4	A	-	N	N	4	2																				

Product
GTE = GTE

Size
060 = 060

Mounting position and operating mode
Arbitrary = NN

Stages
One-stage = 1
Two-stage = 2

Transmission ratio
One-stage: 3 4 5 8 e.g., 4:1 ... = 004
Two-stage: 12 20 40 e.g., 20:1 ... = 020

Output shaft and reduced backlash
With key = A
Plain = B

Designation of mounted motor

Size \ Product	025	030	030B	031B
MKD	NN02	-	-	-
MSK	-	NN02	-	-
MSM	-	-	NN42	NN42

Fig.8-2: Type code GTE060

8.4 Type Code GTE080

ZN-40019-080_NOR_N_EN_2008-09-19.fh11

Abbrev. column	1	2	3	4	5	6	7	8	9	0	1	2	3	4	5	6	7	8	9	0	1	2	3	4	5	6	7	8	9	0	1	2	3	4	5	6	7	8	9	0	
Example:	G	T	E	0	8	0	-	N	N	1	-	0	0	4	A	-	N	N	0	3																					

Product
 GTE = GTE

Size
 080 = 080

Mounting position and operating mode
 Arbitrary = NN

Stages
 One-stage = 1
 Two-stage = 2

Transmission ratio
 One-stage: 3 4 5 8 e.g., 4:1 ... = 004
 Two-stage: 12 20 40 e.g., 20:1 ... = 020

Output shaft and reduced backlash
 With key = A
 Plain = B

Designation of mounted motor

Size \ Product	030	030C	031C	040	040B	041	041B
KSM	-	-	-	-	-	NN03	-
MKD	-	-	-	-	-	NN03	-
MSK	NN02	-	-	NN03	-	-	-
MSM	-	NN43	NN43	-	NN44	-	NN44

Fig. 8-3: Type code GTE080

Type Codes

8.5 Type Code GTE120

ZN-40019-120_NOR_N_EN_2008-09-19.fh11

Abbrev. column	1	2	3	4	5	6	7	8	9	0	1	2	3	4	5	6	7	8	9	0	1	2	3	4	5	6	7	8	9	0	1	2	3	4	5	6	7	8	9	0	
Example:	G	T	E	1	2	0	-	NN	1	-	0	0	4	A	-	NN	0	3																							

Product
GTE = GTE

Size
120 = 120

Mounting position and operating mode
Arbitrary = NN

Stages
One-stage..... = 1
Two-stage..... = 2

Transmission ratio
One-stage: 3 4 5 8 e.g., 4:1 ... = 004
Two-stage: 12 20 40 e.g., 20:1 ... = 020

Output shaft and reduced backlash
With key = A
Plain = B

Designation of mounted motor

Size \ Product	040	040B	041	041B	050	060	061	071
KSM	-	-	NN03	-	-	-	NN05 ①	-
MKD	-	-	NN03	-	-	-	-	NN05 ①
MSK	NN03	-	-	-	NN20	NN21 ①	NN05 ①	-
MSM	-	NN44	-	NN44	-	-	-	-

Note:
① Only available with one-stage gearbox

Fig.8-4: Type Code GTE120

8.6 Type Code GTE160

ZN-40019-160_NOR_N_EN_2008-01-09.fh11

Abbrev. column	1	2	3	4	5	6	7	8	9	0	1	2	3	4	5	6	7	8	9	0	2	1	2	3	4	5	6	7	8	9	0	3	1	2	3	4	5	6	7	8	9	0	4	
Example:	G	T	E	1	6	0	-	N	N	1	-	0	0	4	A	-	N	N	2	1																								

Product
GTE = GTE

Size
160 = 160

Mounting position and operating mode
Arbitrary = NN

Stages
One-stage = 1
Two-stage = 2

Transmission ratio
One-stage: 3 4 5 8 e.g., 4:1 ... = 004
Two-stage: 12 20 40 e.g., 20:1 ... = 020

Output shaft and reduced backlash
With key = A
Plain = B

Designation of mounted motor

Size	050	060	061	070	071	075	076	090	100	112
Product										
KSM	-	-	NN05	-	NN16	-	NN06	-	-	-
MKD	-	-	-	-	NN05	-	-	NN06	-	NN09 ①
MSK	NN20	NN21	NN05	NN16	NN16	NN16	NN06	-	NN09 ①	-

Note:
① Only available with one-stage gearbox

Fig. 8-5: Type Code GTE160

9 Handling, Transport and Storage

9.1 Handling

9.1.1 Identifying the Goods

Transport documents The total scope of a delivery can be seen in the delivery note or waybill. However, the contents of a delivery can be distributed over several packages.

Barcode Label Each motor package is provided with a bar code label providing the following data:

- Type designation
- Customer
- Delivery note number
- Consignment

The bar code label is provided for identification of the contents during processing of the order.

9.1.2 Name Plates

Gearboxes The gearbox is delivered with a name plate. The name plate is attached to the gearbox-housing. The name plate was extended by a 2D-barcode to improve the read-in via barcode scanner and to have an additional possibility to read in.

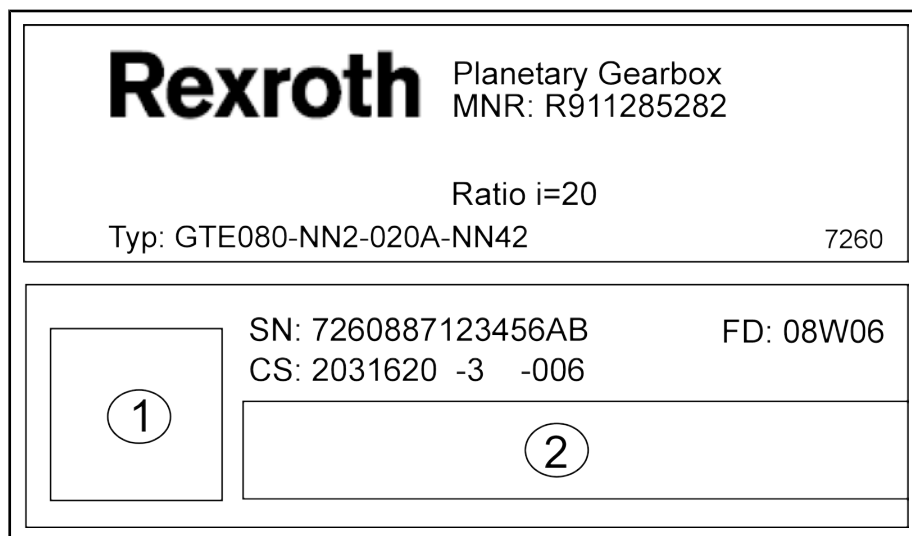

- 1 2D - Barcode
- 2 Barcode

Fig.9-1: Name plate (example GTE gearbox)

Motor-Gearbox Combination

The motor is delivered with its own separate type plate. This is attached to the motor housing. In addition, a second type plate is attached using two-side tape onto the original motor name plate. The second type plate can be attached where visible on the machine, if the original type plate of the motor is concealed by parts of the machine. Because of different national regulations, different type plates are used for motors according to EN and UL-standards. The differences are shown in the following picture.

The type plate is provided for

- identification of the motor
- Procurement of spare parts in case of a fault

Handling, Transport and Storage

- service information

9.2 Transport and Storage

CAUTION

Damage or injuries and invalidation of the warranty due to improper handling!

- ⇒ Avoid mechanical stressing, throwing, tipping or dropping of the products.
- ⇒ Use suitable lifting equipment only.
- ⇒ Never lift up the motor on the optional fan housing.
- ⇒ Use suitable protective equipment and protective clothing during transport; wear safety shoes.
- ⇒ Protect the products from dampness and corrosion.

Gearboxes

Also observe the notes regarding storage and transport on the packages

The gearboxes are typically supplied in recyclable cardboard boxes with carton for shaped elements.

It is recommended to store the gearboxes in their original packaging in a horizontal position until they are ready for use. The permissible temperature range for short-term storage or transport is -20°C up to $+80^{\circ}\text{C}$.

For long-term storage, it is recommended to store the gearboxes in a dry environment with temperatures from 0°C to $+30^{\circ}\text{C}$. The gearboxes can be stored over a period of maximum 2 years under these conditions.

Avoid direct insolation, UV light and ozone because it leads to deterioration of the sealants.

We recommend using a FIFO system - "First-in, first-out".



Remove all the anticorrosive on the gearboxes before mounting them.

The GTE gearboxes are filled-for-life with lubrication and are ready for use. The input and output are treated with anticorrosive coating.

NOTICE

Do not proceed cleaning via air pressure!

The danger consists that overpressure within the gearbox can occur which negatively influences the function and lifetime of the gearbox.

Motor-Gearbox-Combination

The following conditions must be kept during transport and handling:

- Use the appropriate means for transport. Take the weight of the components into consideration (weights are specified in the appropriate "Technical Data" chapters of the various motors and gearboxes and/or on the type label of the motor).
- Transport the motor-gearbox combination only in the horizontal position.
- To lift the motor-gearbox combinations use a crane and lifting sling belts
- Avoid damage to the motor flange and drive shaft.
- Avoid impacts on the gearbox drive shaft.
- Remove the protective cover on the gearbox output shaft just before mounting.

NOTICE

**Motor or gearbox damage and guarantee loss
due to incorrect storage!**

The following conditions must be kept during storage:

- Permissible range of temperature: -20°C to +80°C (only valid for short-term storage or transport. For a long-term storage please keep a temperature range of 0°C to +30°C.)
 - Store motors in dry places which are free from dust and vibrations.
 - Store motors horizontally.
 - Do not remove the plastic protective sleeve on the output shaft. It protects the shaft from moisture, rust and mechanical damage.
-

10 Mounting

10.1 Skilled Personnel

Any work on the system, on the drives, or on the planetary gearboxes or in their vicinity may only be carried out by properly skilled personnel. The owner of the system must ensure that all persons carrying out

- installation works
- maintenance, or
- operating activities

on the system are adequately familiar with the contents of this documentation as well as with all warnings and precautionary measures contained therein. Qualified skilled personnel are defined as those who have been trained, instructed or are authorized to activate and deactivate, ground and mark electric circuits and equipment according to the technical safety regulations. Qualified technical personnel must possess appropriate safety equipment and have been trained in first aid.

10.2 Motor Mounting

10.2.1 General Information

The motor is centered by using pilot diameter of the Bosch Rexroth motor and the appropriate pilot diameter of the gearbox's input flange. The connection between the motor output shaft and gearbox input shaft is established via a compression coupling. The compression couplings are matched to the corresponding motor shaft diameters when necessary by using a slotted bushings. . The clamping connection of the GTE gearboxes present an innovation, which makes a high exactness at assembly possible. The tension results from several closed slots, whereby a precise cylindrical clamping can be reached. The position of clamping ring, bush and motor shaft is irrelevant for assembly.

Before mounting the servo motors to the gearboxes, all parts have to be checked closely for damage. All parts should slide easily and without any force into one another. Damage on the motor drive shaft or to the compression coupling of the gearbox can prevent this and must be avoided.



Every warranty claim expires, if adapter parts are removed or altered.

Damage to or contamination on the motor front flange face or on the gearbox flange face can lead to angular misalignment of the motor drive shaft and the gearbox. This can lead to stress on the connection and will have a negative influence on the noise and life time of the motor and/or the gearbox.

The gearboxes are provided with the proper adapter parts necessary for the stipulated motor type according to the type code in the order. Adapter parts makes it possible for the gearboxes to be mounted on every Bosch Rexroth servo motor listed in the type code.



When combining Bosch Rexroth motors with GTE gearboxes, always choose motors with **smooth shafts**.

10.2.2 Mounting Procedure

If the gearbox and motor have been checked on their quality, the following assembly procedure is recommended.

Mounting

1. Clean and check the parts.

Fig. 10-1: Cleaning of the parts before mounting

Check for damage to the motor shaft, compression coupling bore and any bushing, as well as the faces of motor and gearbox flanges and clean them free from grease thoroughly. Do not clean the parts with compressed air. Avoid using aggressive detergents, which could damage the seals.

2. Remove cap screws.

Fig. 10-2: Remove the cover screws

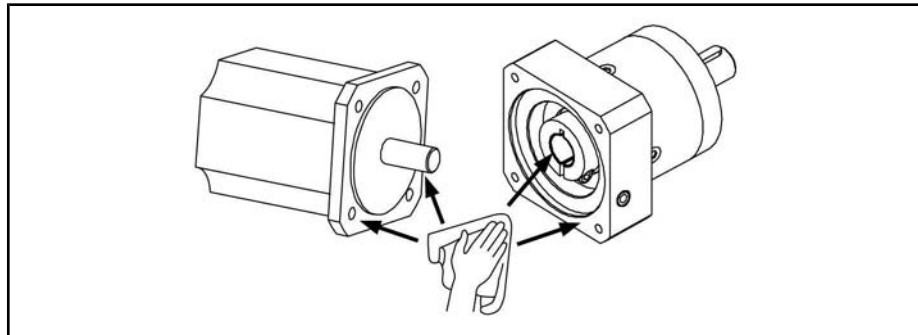
Remove the cover screws from the gearbox connection flange, which covers the access to the clamping screw. Turn the compression coupling so that the heads of the clamping screws line up with the tapped holes, which have now been opened in the gearbox's adapter plate.

3. Insert the motor shaft into the gearbox

Fig. 10-3: Insert the motor shaft into the gearbox

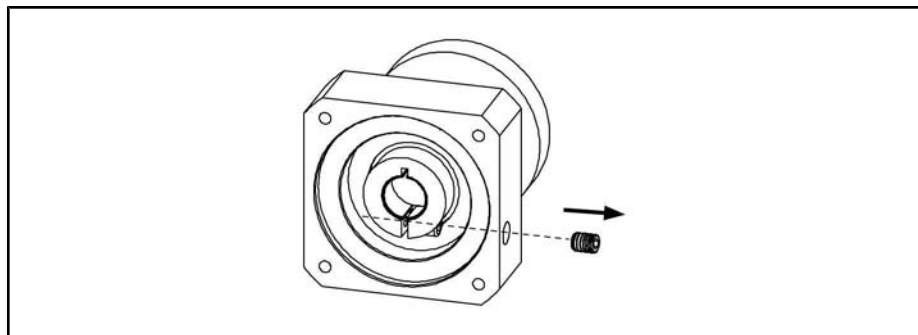
Insert the motor shaft into the gearbox coupling until the gearbox's connecting flange and the motor face are fully in contact. It should be possible to accomplish this without excessive force. The gearbox is equipped with an integrated thermal length compensation to compensate for the thermal expansion of the motor shaft. This compensates the linear extension of the motor drive shaft at temperature rise. When joining the parts together can only be done with high power, high forces occur on the clamping hubs

Mounting

or the motor bearing, which lead to damage on the motor and / or the gearbox.

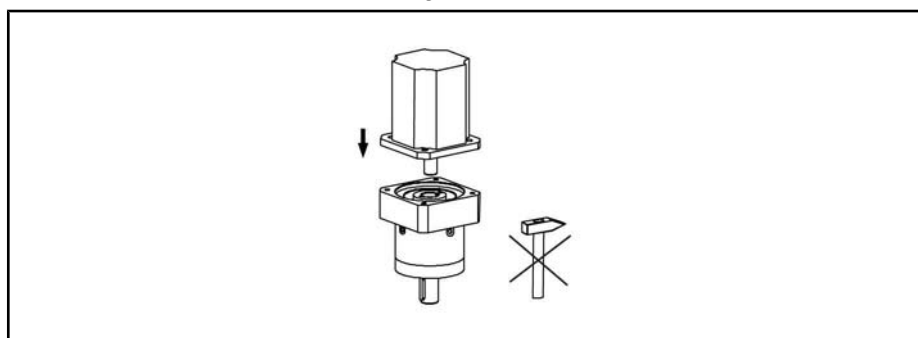

If so, please contact your responsible sales office immediately.

NOTE! Danger of damaged motor bearing and / or gearbox due to bracing during mounting.

- Do the assembly process in vertical position.

4. Connect the motor to the gearbox

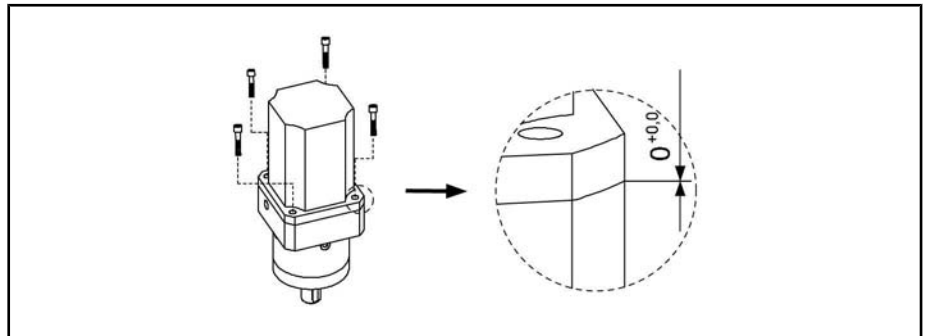

Fig. 10-4: Proper tightening of the clamping bolts.

To assure a proper connection, tighten all fastening bolts with the correct tightening torque according to DIN using the crossover pattern.

5. Reinsert the cap screws.

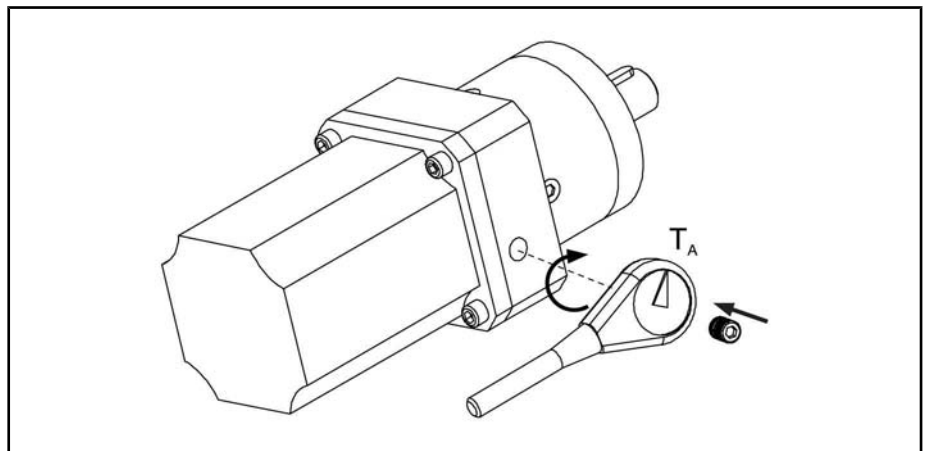

Fig. 10-5: Tightening torque – cap screws

The cap screws must be replaced and tightened with the specified torque (see. Fig. 10-5). To ensure an IP54 sealed drive-system, the cap screws (as described in step 2) have to be re-tightened.

Gearboxes	GTE040		GTE060	GTE080	GTE120	GTE160
shaft diameter	≤ 8	>8	≤ 14	≤ 19	≤ 24	≤ 35
T_A [Nm]	2	4.5	4.5	9.5	16.5	40
SW [mm]	2.5	3	3	4	5	6

Fig. 10-6: Tightening torque

Mounting

10.3 Gearbox Mounting

Remove the protective cap from the gearbox shaft and thoroughly clean the pilot diameter, the contact surface and the output shaft.

Furthermore,

Mounting of the gearbox to the machine (or robot, etc.) is to be made via the output pilot diameter of the gearbox and four through holes on the gearbox housing.

We recommend using ISO 12.9-grade bolts with the proper tightening torques. We also recommend securing the bolts with Loctide.

Gearbox type	Pilot diameter	Bolt size- ISO-grade	Tightening torque
	[mm]		[Nm]
GTE040	26	M4-12.9	5.3
GTE060	40	M5-12.9	10.4
GTE080	60	M6-12.9	18
GTE120	80	M10-12.9	87
GTE160	130	M12-12.9	150

Fig.10-7: Flange-mounting data for installing the gearbox on the machine.

Assure a non-distorted mount when installing the gearbox. Attachments part, like gears or tooth lock washers have to be mounted on the output shaft non-violent. In no case, they should be mounted by beating. Use only appropriate tools or appliances.



To avoid a heat accumulation and therewith the danger of an over-temperature disconnection within the drive-system (gearbox + motor), make sure that during operation an unhindered circulation of air exists.

11 Commissioning, Operation and Maintenance

11.1 Start-Up

11.1.1 General Information

The following commission notes refer to the GTE planetary gearboxes as part of a drive-system with motor, drive and control unit.

11.1.2 Preparation

1. Keep the documentation of all products you are using ready.
2. Log all measures taken in the commissioning log.
3. Check the products for damage.
4. Check all mechanical and electrical connections.
5. Activate the safety and monitoring equipment of the system.

NOTICE

Damage to property due to errors in the controls of motors and moving elements! Unclear operating states and product data!

- Do not carry out commissioning if connections, operating states or product data are unclear or faulty!
- Do not carry out commissioning if the safety and monitoring equipment of the system is damaged or not in operation.
- Damaged products must not be put into operation.
- Contact Bosch Rexroth for missing information or support during commissioning!

11.1.3 Bulk Head Connector

When all requirements are met, proceed as follows:

1. Commission the motors, controllers and power supplies according to the corresponding descriptions. Note the respective product documentation.
2. Before releasing the setpoint, check whether the set relationship of the maximum motor speed and the preset setpoint corresponds to the specifications for the machine.
3. At a low turning speed, check whether the rotation direction of the gearbox and the polarity setpoint correspond to the specifications for the machine.
4. At a low turning speed, check whether the positioning commands of the control systems are executed correctly.
5. Log all measures taken in the commissioning report.

When all steps have been executed correctly, commissioning of the gearbox is complete.



Commissioning of motors and controllers may require additional steps. The inspection of the functioning and performance of the systems is not part of the commissioning of the gearbox; instead, it is carried out within the framework of the commissioning of the machine as a whole. Observe the instructions and regulations given by the machine manufacturer.

Commissioning, Operation and Maintenance

11.2 Deactivation

In the case of malfunctions, maintenance measures or to deactivate the gearbox-motor unit, proceed as follows:

1. Observe the instructions of the machine documentation.
2. Use the machine-side control commands to bring the drive to a controlled standstill.
3. Switch off the power and control voltage of the drive device.
4. Switch off the motor protection switch for the motor fan.
5. Switch off the main switch of the machine.
6. Secure the machine against accidental movements and against unauthorized operation.
7. Wait for the discharge time of the electrical systems to expire and then disconnect all electrical connections.
8. Before dismantling, secure the gearbox-motor unit and supply cables against falling or movements before disconnecting the mechanical connections.
9. Document all done measures in the start-up report and machine maintenance plan.

11.3 Disassembly

DANGER

Fatal injury due to errors in trigger motors and moving elements!

- Do not work on unsecured and operating machines.
- Secure the machine against accidental movements and against unauthorized operation.
- Before dismantling, secure the gearbox-motor unit and supply cables against falling or movements before disconnecting the mechanical connections.

1. Observe the instructions of the machine documentation.
2. Please heed the safety notes and carry out all steps as described in the anterior instructions in the chapter "11.2 Deactivation".
3. Remove the gearbox-motor unit from the machine and store the unit properly.
4. Document all executed measures in the commissioning report or in the machine maintenance plan.

11.4 Maintenance

11.4.1 General Information

Planetary gearboxes of GTE series operate without deterioration within the given operating conditions. However, operation under unfavorable conditions can lead to limitations in availability.

- Observe the information of the machine manufacturer in the machine maintenance plan.
- Log all maintenance measures in the machine maintenance plan.

11.4.2 Measures

⚠ WARNING

Danger of injury due to moving elements! Danger of injury due to hot surfaces!

- Do not carry out any maintenance measures, while the machine is running.
- This work must be carried out only by skilled personnel.
- During maintenance work, secure the system against restarting and unauthorized use.
- Do not work on hot surfaces.
- Protect open supply cables and connections against penetration of pollution.

Bosch Rexroth recommends the following maintenance measures, based on the maintenance plan of the machine manufacturer:

Measure	Interval
Check the mechanical and electrical connections.	According to the guidelines in the machine maintenance plan, but at least every 1,000 operating hours.
Check the gearbox-motor unit for smooth running, vibrations and bearing noises.	According to the guidelines in the machine maintenance plan, but at least every 1,000 operating hours.
Remove dust, chips and other dirt from the gearbox-motor housing, cooling fins and the connections.	Depending on the degree of soiling, but after 6 month operation at the latest. Do it monthly at strong pollution.

Fig. 11-1: Gearbox-motor unit maintenance plan

11.5 Troubleshooting

11.5.1 General Information

⚠ WARNING

Danger of injury due to moving elements! Danger of injury due to hot surfaces!

- Do not carry out any maintenance measures, while the machine is running.
- This work must be carried out only by skilled personnel.
- During maintenance work, secure the system against restarting and unauthorized use.
- Do not work on hot surfaces.
- Protect open supply cables and connections against penetration of pollution.

11.5.2 Excess Temperature of Gearbox Housing

- Status** The housing temperature of the gearbox climbs to unusually high values.
- Possible Causes**
1. The original operating cycle has been changed.
 2. Original drive parameters have been changed.

Commissioning, Operation and Maintenance

- Countermeasures**
1. Check the layout of the drive for changed requirements. Do not operate any longer at overload. Risk of damage!
 2. Reset to the original parameters. Check the layout of the drive in the case of changed requirements.

11.5.3 Gearbox-Motor Unit Generates Vibrations

- Status** Audible or tactile vibrations occur on the gearbox-motor unit.
- Possible Causes**
1. Driven machine elements are insufficient, not balanced or insufficiently coupled.
 2. Gearbox-motor bearings worn or defective. Available bearing lifetime or grease lifetime elapsed.
 3. Gearbox-motor fixing are loosened.
 4. Drive system is instable from a control point of view.
- Countermeasures**
1. Check balance of driven machine elements. Check the key and the key-way. In the case of damage, contact Rexroth Service.
 2. Check the gearbox for damage. In the case of loss, contact Rexroth Service.
 3. Fasten motor properly and check for damage. In the case of loss, contact Rexroth Service.
 4. Check parameters of the drive system (motor and encoder data). Observe the notes in the documentation for the drive controller.

11.5.4 Specified Position is not Attained

- Status** The positioning command of the control unit is not precisely executed, or not at all. No malfunction display on the device controller or the control.
- Possible Causes**
1. Motor drive shaft machine element connection loose.
 2. Motor shaft - gearbox connection loose.
 3. Gearing defective.
- Countermeasures**
1. Check the mechanical connection. Do not continue to use damaged parts.
 2. Check the mechanical connection. Do not continue to use damaged parts.
 3. Change of gearbox necessary. In the case of a malfunction, contact Bosch Rexroth Service.

12 Ordering Designations

12.1 General Information

The planetary gearbox has to be specified as a sub-item of the motor. Preferably, a complete unit, which always consists of planetary gearbox GTE and motor, will be delivered.

Furthermore, heed when ordering the motor that the motor-drive shaft is made as a **plain shaft**.

Ordering example:

- | | | |
|-----|---|----------------------------|
| 1 | 1 | Motor |
| | | Type MSK040-0600-NN-S1-UG0 |
| | | (G = plain shaft) |
| 1.1 | 1 | Planetary Gearboxes |
| | | Type GTE080-NN1-004A-NN02 |
| | | (Mounted on Pos. 1) |

12.2 Notes on Connecting a Motor acc. to ATEX Standard

For more information about ATEX directive and combining a GTE planetary gearbox with an explosion-proof motor (e.g. MSK Motor acc. to ATEX standard), please contact your responsible sales office.



Servo planetary gearboxes acc. to ATEX for mounting on Ex-motors, like MSK motors acc to ATEX Standard are **no** products of Rexroth and will not be offered or delivered neither separately nor mounted.

Basically, assembly of ATEX gearboxes onto Rexroth motors is possible. The gearboxes have to be directly ordered at the supplier and mounted by yourself (for manufacturer recommendation refer to chapter 5.2 "Use of gearboxes or motor-gearbox combinations in hazardous areas (ATEX)).

13 "Old" Technical Data

13.1 "Old" Technical Data for Intermittent and Continuous Operation

Ratio-dependent data

Description	Symbol		Transmission ratio	GTE040	GTE060	GTE080	GTE120	GTE160
Max. input speed ³⁾ min ⁻¹	n _{in, max}	one-stage	i=3	18,000	13,000	7,000	6,500	6,500
			i=4	18,000	13,000	7,000	6,500	6,500
			i=5	18,000	13,000	7,000	6,500	6,500
			i=8	18,000	13,000	7,000	6,500	6,500
		two-stage	i=12	18,000	13,000	7,000	6,500	6,500
			i=20	18,000	13,000	7,000	6,500	6,500
			i=40	18,000	13,000	7,000	6,500	6,500
Max. input torque ¹⁾ Nm	M _{in, max}	one-stage	i=3	1.5	4	13.3	26.7	133.3
			i=4	1.5	4	12.5	25	112.5
			i=5	1.2	3.2	10	22	90
			i=8	0.6	1.9	6.3	15	56.3
		two-stage	i=12	1.7	3.7	10	21.7	66.7
			i=20	1	2.2	6	13	40
			i=40	0.5	1	2.8	5.8	17.5
Max. output speed min ⁻¹	n _{out, max}	one-stage	i=3	6,000	4,333	2,333	2,167	2,167
			i=4	4,500	3,250	1,750	1,625	1,635
			i=5	3,600	2,600	1,400	1,300	1,300
			i=8	2,250	1,625	875	813	813
		two-stage	i=12	1,500	1,083	583	542	542
			i=20	900	650	350	325	325
			i=40	450	325	175	163	163
Max. output torque ¹⁾ Nm	M _{out, max}	one-stage	i=3	4.5	12	40	80	400
			i=4	6	16	50	100	450
			i=5	6	16	50	110	450
			i=8	5	15	50	120	450
		two-stage	i=12	20	44	120	260	800
			i=20	20	44	120	260	800
			i=40	18	40	110	230	700

"Old" Technical Data

Description	Symbol		Transmission ratio	GTE040	GTE060	GTE080	GTE120	GTE160
Nominal input speed ³⁾ min ⁻¹	n _{in, nenn}	one-stage	i=3	4,500	4,000	4,000	3,500	3,000
			i=4	4,500	4,000	4,000	3,500	3,000
			i=5	4,500	4,000	4,000	3,500	3,000
			i=8	4,500	4,000	4,000	3,500	3,000
		two-stage	i=12	4,500	4,000	4,000	3,500	3,000
			i=20	4,500	4,000	4,000	3,500	3,000
			i=40	4,500	4,000	4,000	3,500	3,000
Nominal input torque Nm	M _{in, nenn}	one-stage	i=3	1.5	4	13.3	26.7	133.3
			i=4	1.5	4	12.5	25	112.5
			i=5	1.2	3.2	10	22	90
			i=8	0.6	1.9	6.3	15	56.3
		two-stage	i=12	1.7	3.7	10	21.7	66.7
			i=20	1	2.2	6	13	40
			i=40	0.5	1	2.8	5.8	17.5
Nominal output speed min ⁻¹	n _{out, nenn}	one-stage	i=3	1,500	1,333	1,333	1,167	1,000
			i=4	1,125	1,000	1,000	875	750
			i=5	900	800	800	700	600
			i=8	563	500	500	438	375
		two-stage	i=12	375	333	333	292	250
			i=20	225	200	200	175	150
			i=40	113	100	100	88	75
Nominal output torque Nm	M _{out, nenn}	one-stage	i=3	4.5	12	40	80	400
			i=4	6	16	50	100	450
			i=5	6	16	50	110	450
			i=8	5	15	50	120	450
		two-stage	i=12	20	44	120	260	800
			i=20	20	44	120	260	800
			i=40	18	40	110	230	700

"Old" Technical Data

Description	Symbol		Transmission ratio	GTE040	GTE060	GTE080	GTE120	GTE160
Mass moment of inertia ²⁾ kg cm ²	J	one-stage	i=3	0.031	0.135	0.77	2.63	12.14
			i=4	0.022	0.093	0.52	1.79	7.78
			i=5	0.019	0.078	0.45	1.53	6.07
			i=8	0.017	0.065	0.39	1.32	4.63
		two-stage	i=12	0.029	0.127	0.72	2.56	12.37
			i=20	0.019	0.075	0.44	1.5	6.65
			i=40	0.016	0.064	0.39	1.3	5.28

- 1) at max. 1,000 cycles/h³⁾ do not exceed the permitted operating temperature
 2) Mass moment of inertia of the gearbox referred to the input of the gearbox
 3) Do not exceed the allowed operating temperatures
Fig. 13-1: Ratio-dependent data

General Data

Description	Symbol	Unit		GTE040	GTE060	GTE080	GTE120	GTE160
Backlash ¹⁾	$\Delta\phi$	arcmin	one-stage	<30	<20	<12	<8	<6
			two-stage	<35	<25	<17	<12	<10
Torsion-proof ²⁾	D	Nm/arcmin	one-stage	1.0	2.3	6	12	38
			two-stage	1.1	2.5	6.5	13	41
Efficiency	η	%	one-stage	96				
			two-stage	94				
Lifetime	L_h	H	one-stage	30,000				
			two-stage					
Lubrication			one-stage	Filled for life, closed system				
			two-stage					
Permissible ambient temperature	T_{Um}	°C	one-stage	0...+40°C				
			two-stage					
Permitted gearbox housing temperature ³⁾	T_G	°C	one-stage	-25°C...+90°C				
			two-stage					
Noise level ⁴⁾	L_p	dB(A)	one-stage	≤ 55	≤ 58	≤ 60	≤ 65	≤ 70
			two-stage					
Degree of protection			one-stage	IP54				
			two-stage					

"Old" Technical Data

Description	Symbol	Unit		GTE040	GTE060	GTE080	GTE120	GTE160
Weight	M	kg	one-stage	0.35	0.9	2.1	6.0	18
			two-stage	0.45	1.1	2.6	8.0	22

- 1) with regard to the gearbox output at 3% nominal output torque of the gearbox and locked gearbox input side
 - 2) torsional rigidity of the gearbox with regard to the gearbox output side at locked gearbox input side
 - 3) referring to the middle of the housing surface
 - 4) at gearbox input speed 3,000 min⁻¹
- Fig. 13-2: General Data*



The GTE planetary gearboxes are designed for the indicated specified permitted technical data. With regard to the operating safety it is only allowed to use the gearboxes in this case under view of all operating factors. Any sort of overload of the gearbox is classified as inappropriate use. Any changes on the gearbox exclude all liability on the part of Bosch Rexroth for any damages.

14 Environmental Protection and Disposal

14.1 Environmental Protection

Production Processes	The products are made with energy- and resource-optimized production processes which allow re-using and recycling the resulting waste. We regularly try to replace pollutant-loaded raw materials and supplies by more environment-friendly alternatives.														
Prohibited Substances	We guarantee that our products include no substances according to the chemicals-ban-decree. We furthermore declare that our products are free of mercury, asbestos, PCB and chlorinated hydrocarbons.														
No Release of Hazardous Substances	Our products do not contain any hazardous substances which may be released in the case of appropriate use. Normally, our products will not have any negativ influences on the environment.														
Significant Components	Basically, our products contain the following components: <table><tr><td>Electronic devices</td><td>Motors</td></tr><tr><td>• Steel</td><td>• Steel</td></tr><tr><td>• Aluminum</td><td>• Aluminum</td></tr><tr><td>• Copper</td><td>• Copper</td></tr><tr><td>• Synthetic materials</td><td>• Brass</td></tr><tr><td>• Electronic components and modules</td><td>• Magnetic materials</td></tr><tr><td></td><td>• Electronic components and modules</td></tr></table>	Electronic devices	Motors	• Steel	• Steel	• Aluminum	• Aluminum	• Copper	• Copper	• Synthetic materials	• Brass	• Electronic components and modules	• Magnetic materials		• Electronic components and modules
Electronic devices	Motors														
• Steel	• Steel														
• Aluminum	• Aluminum														
• Copper	• Copper														
• Synthetic materials	• Brass														
• Electronic components and modules	• Magnetic materials														
	• Electronic components and modules														

14.2 Disposal

Return of Products	<p>Our products can be returned to our premises free of charge for disposal. It is a precondition, however, that the products are free of oil, grease or other dirt. Furthermore, the products returned for disposal must not contain any undue foreign material or foreign components.</p> <p>Send the products "free domicile" to the following address:</p> <p style="text-align: center;">Bosch Rexroth AG Electric Drives and Controls Buergermeister-Dr.-Nebel-Strasse 2 97816 Lohr am Main, Germany</p>
Packaging	<p>The packaging materials consist of cardboard, wood and polystyrene. These materials can be recycled anywhere without any problem.</p> <p>For ecological reasons, please refrain from returning the empty packages to us.</p>
Recycling	<p>Most of the products can be recycled due to their high content of metal. In order to recycle the metal in the best possible way, the products must be disassembled into individual modules.</p> <p>Metals contained in electric and electronic modules can also be recycled by means of special separation processes. The synthetic materials remaining after these processes can be thermally recycled.</p> <p>If the products contain batteries or accumulators, these have to be removed before recycling and disposed of.</p>

15 Service and Support

Our service helpdesk at our headquarters in Lohr, Germany, will assist you with all kinds of enquiries. Out of helpdesk hours please contact our German service department directly.

	Helpdesk	Service Hotline Germany	Service Hotline Worldwide
Time ¹⁾	Mo-Fr 7:00 am - 6:00 pm CET	Mo-Fr 6:00 pm - 7:00 am CET Sa-Su 0:00 am - 12:00 pm CET	Outwith Germany please contact our sales/service office in your area first. For hotline numbers refer to the sales office addresses on the Internet.
Phone	+49 (0) 9352 40 50 60	+49 (0) 171 333 88 26 or +49 (0) 172 660 04 06	
Fax	+49 (0) 9352 40 49 41	–	
e-mail	service.svc@boschrexroth.de	–	
Internet	http://www.boschrexroth.com		
	You will also find additional notes regarding service, maintenance (e.g. delivery addresses) and training.		

1) Central European Time (CET)

Preparing Information

For quick and efficient help please have the following information ready:

- detailed description of the fault and the circumstances
- information on the type plate of the affected products, especially type codes and serial numbers
- your phone, fax numbers and e-mail address so we can contact you in case of questions.

Index

A

Ambient temperature.....	25
Application.....	5
Application notes.....	25
Assembly of output elements.....	28
ATEX-Gearboxes.....	27

B

Barcode label.....	61
Bearing lifetime.....	28

C

Calculation of average speed.....	36
Combination possibilities of GTE planetary gearboxes with motors.....	29
Commissioning log.....	69
Contained substances see "Significant components"	79
Continuous operation.....	26
Continuous operation without pause interval (S1).....	22
Continuous operation with pause interval.....	21

D

Deactivation.....	70
Degree of protection.....	34
Dimensioning.....	21
Dimensioning criteria.....	22
Disassembly.....	70
Drive-determined sizes.....	22
Drive system.....	11

E

Efficiency.....	33
Electric drive system.....	11

G

Gearbox mounting.....	68
Gradations.....	6

H

Handling.....	61
Hazardous substances.....	79
Housing temperature.....	71

I

Inappropriate use.....	10
Consequences, exclusion of liability	9
Installation	27
positions	

I

Intended use	
Introduction	9
Intermitted operation.....	26

L

Lifetime.....	33
Limiting temperature curves.....	37
Lubrication.....	33

M

Maintenance.....	70
Manufacturer for ATEX-gearboxes.....	27
Mass moment of inertia.....	33
Max. initial speed.....	31
Max. initial torque.....	31
Max. output speed.....	31
Max. output torque.....	32
Maximum transferable output torque.....	35
Mechanical features.....	27
Mode of functioning.....	6
Motor Mounting.....	65
Mounting.....	65
Mounting procedure.....	65

N

Name plate.....	61
Noise level	34
Nominal initial speed at 100%.....	32, 33
Nominal initial speed at 50%.....	32
Nominal initial torque.....	32
Nominal output torque.....	33

O

Operating conditions.....	25
Operating mode.....	26
Operational reliability.....	6
Ordering designations.....	73
Original packaging.....	62
Output shaft.....	27
Output torque of 100%.....	36
Output torque of 50%.....	36

P

Packaging.....	79
PELV.....	15
Performance data.....	6
Permitted ambient temperature.....	33
Permitted gearbox housing temperature.....	33
Permitted shaft load.....	43
Production processes.....	79
Prohibited substances.....	79

Index

P

Protection class.....	25
Protective extra-low voltage.....	15

R

Reduction at higher cycles.....	26
Return of products.....	79

S

Safety instructions for electric drives and controls.....	11
Selection.....	22
Service Hotline.....	81
Setup elevation.....	25
Shaft load.....	28
Significant components.....	79
Skilled personnel.....	65
Start-up.....	69
Storage.....	62
Support	
see Service Hotline	81
Surface protection.....	25

T

Technical data.....	31
---------------------	----

T

Technical data at increased lifetime.....	37
Technical data for intermittent and continuous operation.....	31
Thermal specifications for S1 operation.....	36
Torsional play.....	33
Torsional strength.....	33
Transport.....	62
Triangular operation with pause interval.....	21
Troubleshooting.....	71
Type Code GTE040.....	55
Type Code GTE060.....	56
Type Code GTE080.....	57
Type Code GTE120.....	58
Type Code GTE160.....	59

U

Use.....	9
----------	---

W

Weight.....	34
-------------	----

Notes

Bosch Rexroth AG
Electric Drives and Controls
P.O. Box 13 57
97803 Lohr, Germany
Bgm.-Dr.-Nebel-Str. 2
97816 Lohr, Germany
Tel. +49 (0)93 52-40-0
Fax +49 (0)93 52-48 85
www.boschrexroth.com

